

UNCLASSIFIED

AD NUMBER

AD390963

CLASSIFICATION CHANGES

TO: UNCLASSIFIED

FROM: CONFIDENTIAL

LIMITATION CHANGES

TO:
Approved for public release; distribution is unlimited.

FROM:
Distribution authorized to U.S. Gov't. agencies and their contractors;
Administrative/Operational Use; 30 MAY 1967.
Other requests shall be referred to Assistant Chief of Staff for Force Development (Army), Washington, DC 20310.

AUTHORITY

30 May 1979, DoDD 5200.10; AGO D/A ltr dtd 29 Apr 1980

THIS PAGE IS UNCLASSIFIED

UNCLASSIFIED

AD NUMBER

AD390963

CLASSIFICATION CHANGES

TO:

CONFIDENTIAL

FROM:

SECRET

AUTHORITY

30 May 1970, DoDD 5200.10

THIS PAGE IS UNCLASSIFIED

THIS REPORT HAS BEEN DELIMITED
AND CLEARED FOR PUBLIC RELEASE
UNDER DOD DIRECTIVE 5200.20 AND
NO RESTRICTIONS ARE IMPOSED UPON
ITS USE AND DISCLOSURE.

DISTRIBUTION STATEMENT A

APPROVED FOR PUBLIC RELEASE;
DISTRIBUTION UNLIMITED.

DISCLAIMER NOTICE

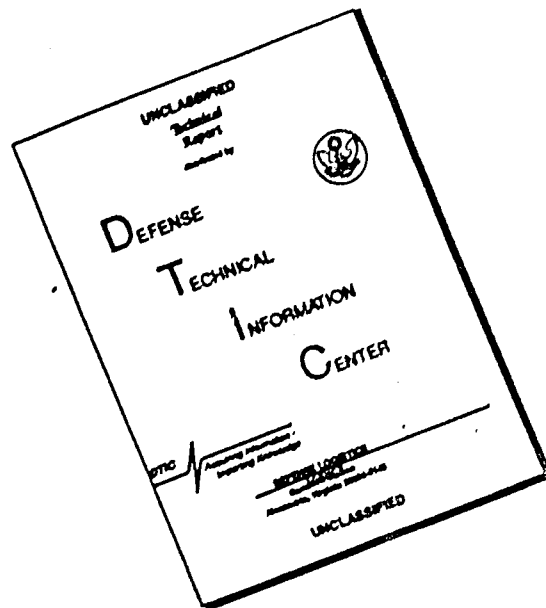

THIS DOCUMENT IS BEST QUALITY AVAILABLE. THE COPY FURNISHED TO DTIC CONTAINED A SIGNIFICANT NUMBER OF PAGES WHICH DO NOT REPRODUCE LEGIBLY.

SECURITY

MARKING

The classified or limited status of this report applies to each page, unless otherwise marked.
Separate page printouts MUST be marked accordingly.

THIS DOCUMENT CONTAINS INFORMATION AFFECTING THE NATIONAL DEFENSE OF THE UNITED STATES WITHIN THE MEANING OF THE ESPIONAGE LAWS, TITLE 18, U.S.C., SECTIONS 793 AND 794. THE TRANSMISSION OR THE REVELATION OF ITS CONTENTS IN ANY MANNER TO AN UNAUTHORIZED PERSON IS PROHIBITED BY LAW.

NOTICE: When government or other drawings, specifications or other data are used for any purpose other than in connection with a definitely related government procurement operation, the U.S. Government thereby incurs no responsibility, nor any obligation whatsoever; and the fact that the Government may have formulated, furnished, or in any way supplied the said drawings, specifications, or other data is not to be regarded by implication or otherwise as in any manner licensing the holder or any other person or corporation, or conveying any rights or permission to manufacture, use or sell any patented invention that may in any way be related thereto.

CONFIDENTIAL



**DEPARTMENT OF THE ARMY
OFFICE OF THE ADJUTANT GENERAL
WASHINGTON, D.C. 20310**

①

REPLY REFER TO
AGAM-P (M) (8 Nov 67) FOR OT RD 670486

17 November 1967

SUBJECT: Operational Report--Lessons Learned, Headquarters, I Field Force Vietnam, Period Ending 30 April 1967

TO: SEE DISTRIBUTION

"This document contains information relating to the defense of the United States under the Espionage Laws, Title 18, U.S.C. Its transmission or disclosure is restricted to authorized personnel only."

1. Subject report is forwarded for review and evaluation by USACDC in accordance with paragraph 6f, AR 1-19 and by USCON. RC in accordance with paragraph 6c and d, AR 1-19. Evaluations and corrective actions should be reported to ACSFOR OT within 90 days of receipt of covering letter.
2. Information contained in this report is provided to insure appropriate benefits in the future from Lessons Learned during current operations, and may be adapted for use in developing training material.

BY ORDER OF THE SECRETARY OF THE ARMY:

Kenneth G. Wickham

KENNETH G. WICKHAM
Major General, USA
Adjutant General

This document has been withdrawn from the DDC bulk storage. It is the responsibility of the recipient to promptly mark it to indicate the reclassification action shown hereon.

1 Incl
as

DISTRIBUTION:

- Commanding Generals
 - US Continental Army Command
 - US Army Combat Developments Command
- Commandants
 - US Army Command and General Staff College
 - US Army War College
 - US Army Air Defense School
 - US Army Armor School
 - US Army Artillery and Missile School
 - US Army Aviation School
 - US Army Chemical School
 - US Army Civil Affairs School
 - US Army Engineer School
 - US Army Infantry School
 - US Army Intelligence School

DD
RECEIVED
JUL 10 1968

REGRADED UNCLASSIFIED WHEN
SEPARATED FROM CLASSIFIED
INCLOSURES

DECLASSIFIED BY
DATE
BY

(Continued on page 2)

RECORDED
670486

CONFIDENTIAL

RB5
2711599

AD390963

FILE COPY

CONFIDENTIAL
CONFIDENTIAL

DISTRIBUTION (Cont'd)

US Army Medical Field Service School
US Army Military Police School
US Army Ordnance School
US Army Quartermaster School
US Army Security Agency School
US Army Signal School
US Army Special Warfare School
US Army Transportation School

Copies Furnished:

Office, Chief of Staff, US Army
Deputy Chiefs of Staff
Chief of Research and Development
Assistant Chiefs of Staff
Chief of Engineers
The Surgeon General
The Provost Marshal General
Research Analysis Corporation (Library)
Dr. Martin J. Bailey, OSD(SA)
National Aeronautics and Space Administration, Office of Defense Affairs
Joint Action Control Office
Commanding Generals
I Field Force Vietnam
US Army Weapons Command
101st Airborne Division (-)
11th Infantry Brigade (Sep)
Commanding Officers
5th Battalion, 46th Infantry
5th Battalion, 12th Infantry
6th Battalion, 31st Infantry
31st Engineer Battalion (Cbt)
5th Battalion, 42d Artillery (155mm-T)
Director, Weapons System Evaluation Group
Documents Control Officer, ATTN: W.M. Smith, Bell Aero Systems

CONFIDENTIAL
CONFIDENTIAL

CONFIDENTIAL

I FFORCEV OPERATIONAL REPORT

NOTICE
This document has been withdrawn from the DDC bulk storage. It is the responsibility of the recipient to promptly mark it to indicate the reclassification action shown hereon.

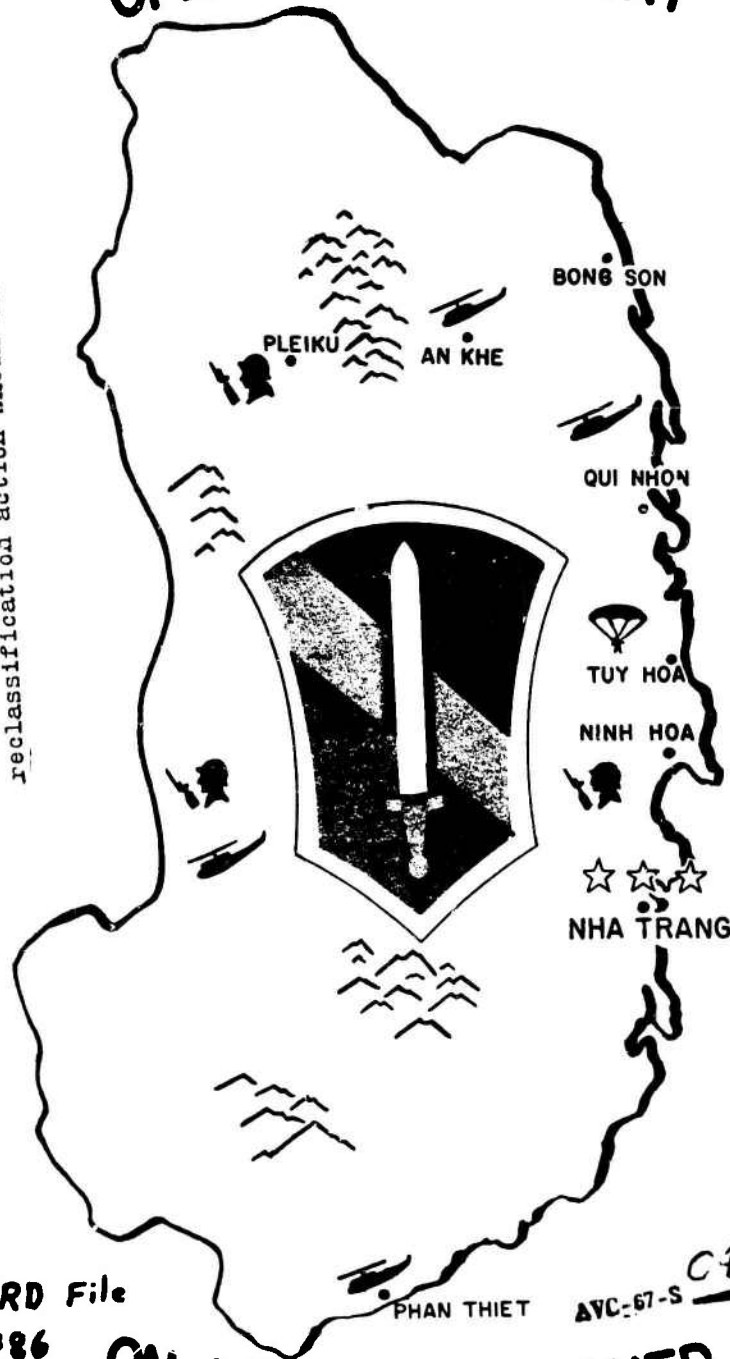

ACSFOR-RD File
670486

ON LESSONS LEARNED

**CONFIDENTIAL
SECRET**

DDC CONTROL
NO.

C435C

AVC-67-S

PHAN THIET

CONFIDENTIAL

OPERATIONAL REPORT ON LESSONS LEARNED

	<u>Para</u>	<u>Page</u>
SECTION I Significant Organization or Unit Activities		
General	1-1b	1
Intelligence	2-2h	1
Operations and Training Activities	3-3h	11
Plans	3a	11
Operational Activities	3b	13
G3 Air Operations	3c	24
Army Aviation Activities	3d	27
Organization and Training Activities	3e	30
Revolutionary Development	3f	32
Psychological Operations	3g	38
Chemical	3h	40
Logistical Activities	4-4e	49
Personnel and Administrative Action.....	5-5g	51
Artillery	6-6q	61
Engineer	7-7b	65
Signal	8-8c	69
Information Office	9-9i	69
Inspector General	10-10c	70
SECTION II Observation (Lessons Learned)		
Operations	1-1b	71
Intelligence	2	72
Logistics	3-3e	72
Other	4-4e	74

REGRADED UNCLASSIFIED WHEN
SEPARATED FROM CLASSIFIED
MATERIAL

FFS 846-67

Of 8 of 25 Cys.

CONFIDENTIAL

DISC CONTROL
NO.

64-5-67-1587

829 Y.1

CONFIDENTIAL

PAGE -1-

5
1
DEPARTMENT OF THE ARMY
HEADQUARTERS (1) FIELD FORCE VIETNAM (1)
APO San Francisco 96350

AVFA-GC-OT

30 May 1967

SUBJECT: Operational Report, ~~Quarterly~~ for Quarterly Period
Ending 30 April 1967. (U)

TO: SEE DISTRIBUTION

10 OACSFOR (19) OT-RD-670483

SECTION I - SIGNIFICANT ORGANIZATION OR UNIT ACTIVITIES

1. (S) General:

a. In January, February, and March 1967, United States and Free World Military Forces (FWMF) with 41 maneuver battalions, 23 US and 18 ROK, supported by 23 artillery battalions, and Army Vietnam (ARVN) with 30 maneuver battalions supported by 6 artillery battalions, continued operations primarily in the west along the Cambodian-Republic of Vietnam (RVN) border in Darlac, Pleiku and Kontum Provinces; and along the east coast in Binh Dinh, Phu Yen and Binh Thuan Provinces. Along the Cambodian/RVN border combat operations were primarily oriented toward interdiction of enemy infiltration routes. On the east coast operations were oriented on search and destroy and revolutionary development.

b. During the reporting period US/FWMF in II Corps Tactical Zone kill ratio was 7.38 to 1. Enemy losses for the period were 5119 KIA (BC), 2470 captured, 2136 individual and 141 crew served weapons captured. This is an increase over the last reporting period of 850 KIA (BC), 1267 captured, 430 individual and 7 crew served weapons captured. Additionally II Corps Tactical Zone accounted for 3,290 Hoi Chanh.

2. (C) Intelligence:

a. General: During the past quarter there were no major changes in staff activities. A series of monthly intelligence staff conferences designed to improve the production and dissemination of intelligence has proven to be highly beneficial to the intelligence community in II CTZ. The last such conference was held at this headquarters on 24-25 March 1967. Conference included CG, I FFORCEV, Director of OCO for Region 2, Director of OSA, J2 ROKV-PC, SIA II Corps, G2 II Corps, and the G2/S2's of all major units OPCON to this headquarters. Subjects discussed were: Dissemination of Information, Intelligence Reports of the Arc Light program, counter-intelligence activities, elimination of the infrastructure, CHIEU HOI program, handling of detainees and PWs, aerial recon and surveillance, and the visual recon program.

b. Significant Sources, Agencies, and Techniques:

(1) There were no major changes in sources, agencies or techniques noted during the reported period.

(2) The lack of photo copier and the shortage of linguists continued to detract from the overall intelligence effort.

(3) Activities of Detachment D, 1st MI Bn (ARS): The detachment continued its mission of imagery interpretation and reproduction and delivery of photography to field units. In addition, detachment personnel continued

CONFIDENTIAL

FTS 846-57

84-5-67-15-5

DOWN GRADED AT 3 YEAR INTERVALS
DECLASSIFIED AFTER 12 YEARS
DOD DIR 5200.10

~~CONFIDENTIAL~~

6

AVFA-OC-OT

SUBJECT: Operational Report for Quarterly Period Ending 30 April
1967, RCS GSPOR-65 (U)

training and advising US and FMAF personnel in the use of the 35mm hand held camera as well as in the development of film and printing of photographs. Detachment personnel also conducted 35mm photo missions for Hq, I FFORCE, 9th ROK Inf Div and II Corps Advisory Group and participated in photographic coverage of combat operations.

(4) During the period, 392 individual weapons, 42 crew served weapons, 12,555 pounds of uniforms and equipment, 772 pounds of medical supplies, 32 tons of signal equipment and 1829 items of munitions were evacuated to Saigon for technical intelligence examination. Interrigation teams in support of combat operations were deployed to Phan Thiet, Pleiku Tuy Hoa, Bong Son, Uplift, Ninh Hoa and Qui Nhon. These teams screened 2997 detainees and interrogated 126 captives and 50 Hoi Chanh. Two thousand five hundred and fifty nine feet of documents were screened and forwarded to the Combined Document Exploitation Center in Saigon for exploitation. The Engineer Detachment processed and distributed 12,500 over print maps to OPCON units.

c. Deviations from current intelligence doctrine: No changes from previous quarter.

d. Significant changes from previous report: None

e. Enemy Order of Battle:

(1) Disposition of NVA, VC Main Force and VC Local Force is shown in inclosure 1.

(2) NVA and VC regular and irregular forces continued to suffer heavy losses throughout the II CTZ during the reporting period. It appears that the enemy is experiencing extreme difficulty in replacing combat losses. Confirmation of new units in II CTZ during the period include the B3 Front Headquarters in the western highlands, the 304th Local Force Battalion in Kontum Province and the 551st Signal Battalion in Binh Dinh. There has been no evidence of major unit infiltration into the Corps area. Available evidence indicates that at least 1600 personnel have infiltrated into the Corps Zone since 1 Jan 67. These were primarily replacement personnel for the 3d and 5th NVA Divs located along the coast.

(3) Enemy Losses during the period:

FEBRUARY 1967

<u>FORCES</u>	<u>KIA</u>	<u>*DOW & DISABLED</u>	<u>VCC/NVA</u>	<u>INDIV WPMS</u>	<u>C/S WPMS</u>
US	900	315	306	293	27
FMAF	640	224	106	307	39
ARVN	198	69	174	62	0
TOTAL	1738	608	586	662	66

~~CONFIDENTIAL~~

7

CONFIDENTIAL

AVFA-OC-OT

SUBJECT: Operational Report for Quarterly Period Ending 30 April
1967, RCS CSFOR-65 (U)

HOI CHANHS 1445

MARCH

<u>FORCES</u>	<u>KIA</u>	<u>WOW & DISABLED</u>	<u>VCC/NVA</u>	<u>INDIV WPNS</u>	<u>C/S WPNS</u>
US	1286	450	687	333	25
FMMAF	429	150	248	315	12
ARVN	194	68	121	122	0
TOTAL	1909	668	1056	770	37

HOI CHANHS 1096

APRIL

<u>FORCES</u>	<u>KIA</u>	<u>WOW & DISABLED</u>	<u>VCC/NVA</u>	<u>INDIV WPNS</u>	<u>C/S WPNS</u>
US	725	254	472	206	7
FMMAF	636	222	279	463	31
ARVN	111	39	77	35	0
TOTAL	1472	515	828	704	38

HOI CHANHS 749 (1-21 April)

(4) Enemy strength within II CTZ as of 30 April 1967.

21,022 - NVA Troops

11,350 - VC Regulars (LF&MF)

4,342 - Administration Service

16,041 - Military (VC Irregulars)

12,585 - Political Cadre

65,340 - TOTAL

* Based on MACV guidance that for every 100 enemy killed by body count, an additional 35 die of wounds or are disabled permanently.

f. Weather:

(1) Interior:

(a) 1 Feb 67-17 March 1967: The only significant weather during this period was morning ground fog. The visibility was one to three miles during the period 0500-1000H. The fog was located mostly along rivers and in mountain valleys. The visibility was seven to ten miles at all other times. The clouds were 3000 ft scattered during the day and skies were usually clear at night. No precipitation was reported during this period. The surface wind was northeast seven to ten knots.

CONFIDENTIAL³

CONFIDENTIAL

8

AVFA-GC-OT

SUBJECT: Operational Report for Quarterly Period Ending 30 April
1967, RCS CSFOR-65 (U)

(b) 17 March 1967-1 April 1967: Patchy morning fog restricted the visibility to one to three miles along rivers and in mountain valleys. Haze restricted the visibility to a general three to five miles during the day. Isolated thunderstorms and/or rainshowers appeared during this period causing brief 2500 ft broken clouds. The surface wind was northeast seven to ten knots.

(c) 2-30 April 1967: The occurrence of fog was greatly reduced during this period. It existed in widely isolated patches from sunrise to 0800H with the visibility restricted to one half to two miles. Haze continued to restrict the visibility to three to five miles during the day until 20 April when increased thunderstorm activity dissipated this haze. Isolated rainshowers and/or thunderstorms occurred each day causing 1500-3000 ft broken-overcast clouds and the visibility restricted to three to five miles from 1500H-2200H. The clouds over the central mountains were generally 2000 ft scattered-broken and elsewhere generally 3000 ft scattered.

(2) Coast North of Phan Rang: From 1 Feb 67-29 March 1967, dominant weather conditions were 1000-2500 ft broken clouds with rainshowers until 1000H. The clouds became scattered at 2000-4000 ft for the rest of the day. Fog was present most mornings restricting visibility to one half to two miles until 0900H. Then the visibility was seven to ten miles for the rest of the day. The surface wind was northeast 10-15 knots during the day and northwest five to eight knots during the night. Noteworthy exceptions to these conditions occurred on 2-3 February, 13-16 February, 26 February-2 March, and 4-11 March when strong surges in the monsoonal flow occurred. Very low clouds, 500-1200 ft overcast were present during the mornings becoming 1500-3000 ft broken by 1200H. Rainshowers, occasionally heavy, were present each day, and they restricted the visibility to one half to three miles. The surface wind was northeasterly with gusts as high as 40-50 kts.

(3) Coast South of Phan Rang: From 1 Feb 67 to 29 March 1967 dominant weather conditions were 3000 ft scattered clouds with the visibility seven to ten miles. Exceptions to these conditions occurred with the strong monsoonal surges previously noted. The clouds were 2000-3000 ft broken and a few light rainshowers occurred during the morning. The surface wind was northeasterly with gusts to 30-40 kts.

(4) Entire Coast: From 30 March 1967 to 30 April 1967 the northeast monsoon flow decreased and improved weather conditions were noted. Clouds were normally 3000 ft scattered except during the morning hours until 1000H when clouds were 2000-3000 ft scattered-broken. During the afternoons isolated rainshowers were present causing brief 2000 ft ceilings. On the mornings 15-26 April isolated rainshowers and/or thunderstorms occurred 0200-0700H. During this period fog was present along the rivers and valleys that extend out to the coast. The visibility was one half to two miles in the fog improving by 1000H to four to seven miles in some haze. Haze dissipated after 20 April due to increased thunderstorm activity. The surface wind during this period was easterly 10-18 knots during the day and northwest seven to ten knots at night.

(5) Effects of weather on operations were numerous. One troop movement was cancelled, and one was delayed. One unit could not receive air support nor evacuate their wounded by Dustoff. A total of 497 TAC AIR sorties were cancelled, 66 in February, 266 in March, and 165 in April. There were a total of 32 Trail dust missions cancelled, 0 in February, 9 in March, and 23 in April.

4

CONFIDENTIAL

9
CONFIDENTIAL

AVFA-GC-OT

SUBJECT: Operational Report for Quarterly Period Ending 30 April
1967, RCS CSFOR-65 (U)

g. Significant Enemy Activities.

(1) After suffering major defeats during the last half of 1966 and the first half of 1967 throughout the Corps Tactical Zone, the enemy is now believed to be implementing a military strategy based on the Lao Dong Party Resolution Number 12, which calls for a campaign to create favorable opportunities for a decisive military victory prior to peace negotiations.

(2) The enemy will probably attempt to implement this strategy by first building his forces up in remote areas contiguous to the coastal plain, at the same time keeping friendly forces occupied by a series of small indecisive engagements until his buildup is complete. The second phase of his strategy may be a series of battalion-sized attacks along the coastal plain to draw friendly forces from the Western Highlands. The final phase of his strategy would be to launch a massive offensive operation in the Western Highlands designed to destroy the remaining friendly forces in that area. This offensive could be launched with as many as three divisions, and would be an effort to gain a major military victory prior to entering into political negotiations.

(3) There are indications that at the present time this strategy is being implemented in phases. The enemy is building up his forces in three remote areas adjacent to the coastal plains, and is apparently giving these units priority for replacements over units in the Western Highlands. There is considerable evidence to indicate that the B3 Front is now operating with only five regiments, including one in Kontum. The 33d and 101C NVA Regt were apparently broken up to provide fillers for other units. The 3d Bn, 33d Regt was identified in Darlac Province in early February 1967 through documents and prisoners. The prisoners stated that they were moved from Cambodia to Darlac to work with local forces. Documents established their subordination to the Darlac Provincial Committee. The identification of this unit focused attention on eastern Darlac as one area where a steady buildup had been taking place since the early part of January 1967. Six months ago only one local force battalion was carried in the entire province. During this period, the D2 Main Force Bn cadred by NVA, was identified. Additionally, a 250-man infiltration group was described by a rallier, and a local force battalion was alleged by four ralliers to have moved from Tay Ninh to Darlac. Shortly after the first of the year, the 5th NVA Div moved from the Haroi Base Area to eastern DARLAC. The 18B NVA Regt moved from Phu Yen to western Khanh Hoa. The 95th NVA Regt, at approximately half strength following a series of heavy losses at the hands of the 1st Bde, 101st Abn Div, in November 1966, moved in January 1967 from Haroi to the Ky Lo Valley area in northwestern Phu Yen along with the 30th Main Force Bn, which normally operates along the coast. Reports indicate that HQ, 5th NVA Div, joined the 95th Regt in the Ky Lo Valley area during March 1967, with indications of about 10 battalions available to the 5th NVA Div. A significant threat exists in eastern Darlac, Phu Yen, and Khanh Hoa provinces.

(4) The second area of buildup has been southern Quang Ngai, where at least four regiments of the 2d and 3d NVA Divs are presently available for commitment within Quang Ngai and/or Binh Dinh. The success of the 1st Cav Div (AM) in Binh Dinh has exceeded all expectations with the enemy suffering his most significant defeats of the war in II CTZ. Because he could not afford to completely evacuate Binh Dinh, the enemy left the 18th Regt to fend for itself while withdrawing the 2d VC Regt to southern Quang Ngai at about one-third strength. The 1d VC Regt was reconstituted in November 1966 and has been out of contact since that time. The 18th Regt

5
CONFIDENTIAL

CONFIDENTIAL

10

AVFA-GC-OT

SUBJECT: Operational Report for Quarterly Period Ending 30 April
1967, RCS CSFOR-65 (U)

was involved in a series of engagements from mid-September 1966 until 17 December 1966, and was reduced to a strength of approximately 600-700. The 18th Regt reappeared in contact on 4 March 1967 when it mortared the CP of the 41st ARVN Regt near Highway 1. During the two and one-half months that the regiment was out of contact, it received replacements from the 400th Mortar Bn and undoubtedly some replacements infiltrated from NVN. The 22d Regt, which has habitually operated north of Bong Son, and which was not involved in major engagements last fall in Binh Dinh, took advantage of the Christmas truce, moved south to the EAGLE'S CLAW area and on 27 Dec 66 attacked an artillery fire base of the 1st Cav Div (AM). The 1st Cav Div (AM) was successful in blocking the regiments primary escape routes and over 200 enemy KIA were counted after the battle. The 22d Regt then withdrew to its normal AO and continued his efforts to resist the 1st Cav Div (AM) in Operation PERSHING. It has suffered small but steady losses in the Bong Son plains, and its overall effectiveness as a regiment at the present time is unknown. Both the 22d NVA Regt and 3d Div HQ have made maximum use of the II/I Corps boundary during the period.

(5) The third area of buildup in the east is on the Binh Thuan-Lam Dong border. In November 1966, HQ, MR VI, moved from western Lam Dong to the Binh Thuan border, probably to improve its control of operations in the coastal provinces of Binh Thuan and Ninh Thuan and as a reaction to the success of friendly operations in Binh Thuan. Since the move of this headquarters, NVA infiltrators have appeared in both Ninh Thuan and Binh Thuan assigned to local force units. In addition the 840th MF was also moved from Quang Duc to Binh Thuan some time since the first of the year. PW's taken during current operations have mentioned several new battalion designations which are being closely checked.

(6) If the enemy is successful in threatening the coastal provinces and in setting the stage for an attack in the west, it is estimated that he would require a three division force to achieve the type of success which would lead to negotiations. He has not been successful in the past with two division operations. There has apparently been a considerable buildup in southern LAOS, and the possible formation of a third division with its attendant threat to the Western Highlands cannot be overlooked.

(7) Except for patrol actions, the Western Highlands were relatively quiet during December 1966 and January 1967, with the enemy's center of gravity remaining in the same area as it was in October 1966. Commencing in February 1967, new tactics in the west began to emerge with the enemy launching a series of indecisive attacks against CIDG camps, fire bases, and deployed units. During the period 15-20 March 1967, over 1500 rounds of mortar fire were received and over 50 mines encountered in the Western Highlands area. Enemy tactics, which continued to the end of the period, were to inflict maximum casualties with minimum loss of life. He has employed heavy firepower to include mines, but has rarely followed these up with ground contact. In conjunction or as an integral part of this strategy he has launched a program of guerrilla warfare in Pleiku Province, an area heretofore considered unsuitable for this type warfare. Despite this strategy the enemy has suffered significant losses during the past several months in Operation SAM HOUSTON with 714 killed, (largely from air and artillery).

(8) Infiltrations:

(a) The key to whether the enemy can in fact execute his long range strategy is based on his ability to infiltrate far more NVA into

6
CONFIDENTIAL

CONFIDENTIAL

AVFA-GC-OT

SUBJECT: Operational Report for Quarterly Period Ending 30 April
1967, RCS CSFOR-65 (U)

the country than he did between July 1966 and January 1967. During this period no new NVA units appeared in the corps area, and the infiltration that took place was apparently personnel to be used as fillers for units already in being. Since November 1966 there have been 26 reports of cannibalization of up to regimental size units to reinforce other units. However, since the beginning of the year, there has been evidence that the enemy is once again attempting sizeable infiltration.

(b) It is estimated that approximately 400 replacements have been received by elements of the 3d NVA Div, with 200 to 300 of these going to the 22d Regt and the remainder probably going to the 18th Regt.

(c) In eastern Darlac the move of the 3d Bn, 33d Regt has been previously mentioned, as has the move of the C320th Bn from Tay Ninh. The 250 man infiltration group also previously mentioned and referred to as the 326th Bn, was reported by one rallier to have left NVN in October 1966 and arrived in DARLAC Province in December 1966 with its 3d Company going to Khanh Hoa Province. Three PW's recently apprehended in Phu Yen Province indicated that the 95th Regt of the 5th Div received up to three companies of replacements in December 1966 from Darlac Province. One of the PW's stated that these recently infiltrated replacements had been diverted from the 10th Div to the 5th Div due to the latter's critical shortage of personnel.

(d) In the Western Highlands, agent reports since January 1967 continue to indicate movement of infiltration groups from company to regimental size down the main corridor past the Chu Pong through the Nam Lyr base area, then into SVN. Of significance is the fact that there are no known indications of these groups reinforcing the B3 Front. In fact, a PW from the 88th NVA Regt captured in the Plei Trap Valley on 15 March 1967 gave the strength of his company as only 42. He stated that in February 1967 while he was in Cambodia he had talked to some NVA who belonged to a six company replacement group. The NVA said that they had been traveling for two months from the north and had two months to go before they would reach their destination in Hai Yen (III Corps). It appears that units in the Western Highlands are being bypassed at this time, and that the 3d and 5th NVA Divs are now receiving priority in personnel replacements, some going to local force VC units with the B3 Front to be built up at a later time. It is also significant that the friendly OMEGA and guerrilla forces operating along the border in recent months have found no indications of major infiltration.

(9) Enemy Situation at Close of Period

(a) The enemy continued to avoid major contact throughout the month of April 1967. There was a marked increase in his efforts to disrupt the pacification program primarily in the coastal areas.

(b) The most significant development in II CT3 was the apparent shift of enemy forces in Cambodia from the southwest Kontum-Plei Trap area to the Chu Pong-Duc Co-Plei Me area. A battalion size NVA contact and the discovery of numerous new bunker complexes south of Highway 19 indicates that the enemy is preparing the battlefield for future operations. Current intelligence indicates that as a result of heavy casualties units of the B3 Front have undergone a major reorganization. Evidence indicates that the 1st NVA Div now consists of the 32d, 66th and 88th NVA Regt, and that the 24th and 95B NVA Regt are now directly subordinate to the B3 Front Headquarters. Although it now appears that Headquarters, 10th NVA Division, does not, at the present time, have any

CONFIDENTIAL

12

CONFIDENTIAL

AVFA-GC-OT

SUBJECT: Operational Report for Quarterly Period Ending 30 April
1967, RCS CSFOR-65 (U)

subordinate regiments, there is not sufficient evidence to indicate that it has been disbanded.

(c) In Binh Thuan the possible presence of a regimental size unit poses an increased threat to the triangle area north of Phan Thiet which contains the bulk of the population of Binh Thuan.

(d) Preliminary information from a document captured by ARVN in January 1967 states that a new military region has been formed. The new region includes Quang Duc, Phuoc Long and Binh Long Provinces. The mission of this region is to establish the largest and safest base area in SVN. The 7th NVA Div has been assigned to this area.

h. Enemy Capabilities, Vulnerabilities and Probable Courses of Action: Based on the enemy's order of battle and trends at the end of the period, the enemy's capabilities, vulnerabilities and probable courses of action were viewed as follows:

(1) Enemy Capabilities:

(a) In the Western Highlands, attack at any time with up to four regiments which have an estimated combat effective strength equivalent up to seven full strength battalions, along a front ranging from the Chu Pong mountain north to the upper Plei Trap Valley. This attack could be supported by divisional artillery from Cambodia and be reinforced by the 24th NVA Regt from Kontum currently operating under MR 5 control and one local force battalion.

(b) In Binh Dinh Province and southern Quang Ngai Province attack separate objectives in an area ranging from the Kim Son Valley north to Ba To USSF Camp with five combat effective battalions supported by two local force battalions and district forces.

(c) In Khanh Hoa Province, attack in regimental strength in the northern or southern part of the province with support from district forces.

(d) In Phu Yen Province, attack with one understrength regiment in the northern or central areas of the province along with one MF battalion (30th) in conjunction with diversionary attacks by LF units.

(e) In Darlac Province attack with up to one battalion NVA and reinforce with up to one battalion VC LF.

(f) In Binh Thuan attack with up to two battalions and five independent local force companies.

(g) In the remainder of II CTZ, attack with LF and MF units of up to multi-battalion strength supported by district and guerrilla forces.

(h) Attack isolated outposts, installations, and units with up to reinforced battalion strength in any province with attempts to ambush relief forces.

(i) Continue harassment, sabotage, assassination, and probing activities.

(2) Enemy Vulnerabilities:

8
CONFIDENTIAL

CONFIDENTIAL

AVFA-GC-OT

SUBJECT: Operational Report for Quarterly Period Ending 30 April
1967, RCS CSFOR-65 (U)

(a) Enemy is generally short of medicine and food supplies, and in the coastal area is experiencing difficulties in providing individual replacements for NVA and VC units.

(b) Enemy LOC's are extended and insecure, with the exception of those traversing neutral countries or international waters where some degree of security exists.

(c) Low enemy morale is vulnerable to exploitation by friendly psychological warfare operations.

(3) Discussion and Analysis: The enemy situation in Binh Dinh has been earmarked by the enemy's determination to remain in the area, and in fact, to regain control of the province if possible. All three regiments of the 3d NVA Div are reported to have received replacements during the period December 1966 to March 1967, and are once again believed to be combat effective. Although considered combat ineffective in December 1966, and reduced to a strength of approximately 600, the 18th Regt reasserted itself in central Binh Dinh in March 1967 with an attack on an ARVN CP. Indications are that the regiment is operating in battalion size formations with primary mission of disrupting the pacification program. The 2d VC Regt and the 22d Regt remain in vicinity of the I-II Corps border and have the capability of moving into Binh Dinh and launching offensive operations at a time and place of their own choosing. The E2B En which was decimated during the Phu Cat Mountain Operation, may once again be a combat effective unit. The enemy will probably intensify his efforts to regain control of Binh Dinh by destruction of the Revolutionary Development Program in order to regain control of the population and food resources. In the Western Highlands the enemy continues his attempts to keep sizeable US forces engaged by conducting small scale mortar attacks and increasing the intensity of his mining and other harassing activities. There has been no concrete evidence that the enemy is yet reinforcing his forces in the Western Highlands; however, by use of his Cambodian sanctuary, reinforcements could be received without our knowledge. It appears the NVA units on the east coast are being built up before those in the west. In Phu Yen the 5th NVA Div continues to avoid contact while local VC direct their efforts against RD cadre. This division will undoubtedly participate in the summer campaign. In Binh Thuan the possible presence of a regimental size unit poses an increased threat to the triangle area north of Phan Thiet which contains the bulk of the population of Binh Thuan Province.

In summary, the enemy has been steadily building up his forces in the coastal areas in an attempt to regain control of the population and other resources lost as a result of FWMAF operations during 1966.

(4) Relative Probability of Adoption:

(a) Avoid decisive contact with major US/RVN/FWMAF forces, unless a favorable opportunity for local success becomes apparent, while continuing to harass vulnerable units and installations. At the same time he will attempt to keep friendly forces occupied in the Western Highlands while continuing to infiltrate units into areas contiguous to the coastal plains in preparation for a major offensive.

(b) Attempt to augment his forces in the Western Highlands by at least one more division.

CONFIDENTIAL

CONFIDENTIAL

14

AVFA-GC-OT

SUBJECT: Operational Report for Quarterly Period Ending 30 April
1967, RCS CSFOR-65 (U)

(c) Attack in up to regimental strength in northern Binh Dinh, southern Quang Ngai, Phu Yen, Khanh Hoa or eastern Darlac supported by LF and MF units in an attempt to draw friendly forces from the Western Highlands.

(d) Attack in multi-regimental strength in the western highlands in order to destroy remaining forces, in order to achieve a significant victory prior to negotiations.

CONFIDENTIAL

15

~~SECRET~~

AVFA-GC-OT

SUBJECT: Operational Report for Quarterly Period Ending 30 April
1967, RCS CSFOR-65 (U)

3. (S) OPERATIONS AND TRAINING ACTIVITIES

a. Plans: Based on guidance, intelligence, and the overall concept of strategy for conducting operations, the G3 Plans Division formulated and published five OPLANS and ten FRAG ORDERS for tactical operations, the following major actions were accomplished: Defoliation Plan for II CTZ; Preparation of 1967 Combined Campaign Plan for II CTZ for the second half of the year; and made provisions for deployment of I FFORCEV assets to I CTZ (Project OREGON).

(1) OPLAN and FRAG ORDERS

(a) OPLAN 132-67 (HANCOCK) was published 10 Feb 67 to employ on a contingency basis, one battalion task force from 4th Inf Div to conduct search and destroy and anti tax operations vicinity plantations in the Ban Me Thout area. Duration of operation was approximately 15 days.

(b) FRAG ORDER 3-67 (DAWES) with change one, employed Project OMEGA in a border surveillance role vicinity Dak To for a 30 day period beginning 3 March 1967.

(c) FRAG ORDER 7-67 (GATLING) and 9-67 (GATLING II) employed the 1st Bde, 101st Abn Div in the sixth military region area. Operation began as a surprise raid against a reported meeting of military and political leaders from Headquarters Sixth Military Region Area. Operation began 1 Feb 67 and was terminated 15 Feb 67.

(d) FRAG ORDER 19-67 (BLACK JACK 23) with change one, employed Mobile Guerrilla Force 876 on or about 5 March 1967 for thirty days to interdict enemy installations and units within capabilities, vicinity An Lao Valley. Operation was under operational control of the 1st Cav Div (AM).

(e) FRAG ORDER 20-67 (KNOX) employed Project DELTA to perform reconnaissance and patrolling in the An Lao Valley area in direct support of 1st Cav Div (AM). Operation began on or about 5 March 1967 for a duration of approximately 30 days.

(f) OPLAN 133-67 (DECATUR) a contingency plan was published on 29 March 1967 as a completely revised plan to replace OPLAN FRANKLIN. DECATUR provides for deployment of forces on a contingency basis, from a rifle company to a division (-) to relieve/reinforce USSF/CIDG camps, province/district headquarters, critical region forces/popular forces outposts and critical signal sites in II CTZ. OPLAN provides for assignment of provinces to I FFORCEV maneuver units and is updated periodically to reflect current positioning of OPCON units.

(g) OPLAN 206-67 (EDISON) was published on 13 March 1967 in response to a MACV Top Secret requirement to intensify border surveillance of known and suspected infiltration routes from Laos into South Vietnam. OPLAN EDISON envisioned employment of Project OMEGA, Mobile Guerrilla Forces, CIDG assets and a one battalion infantry task force in phased component operations to conduct surveillance and interdiction of enemy infiltration routes, destroy targets to be attacked by air and conventional forces. Duration of Operation EDISON: 3 March thru 31 May 1967. Location: Kontum Province.

(h) FRAG ORDER 23-67 (BLACK JACK 24) employed Mobile Guerrilla Force 777 in northwest Kontum Province to conduct border surveillance beginning 15 March 1967 for approximately 30 days.

11

~~SECRET~~

SECRET

16

AVFA-GC-OT

SUBJECT: Operational Report Quarterly Period Ending 30 April
1967, RCS CSFOR-65 (U)

(i) OPLAN 205-67 (SUMMERALL) was formulated to conduct operations against NVA/VC forces in eastern Darlac and western Khanh Hoa Provinces vicinity Buon Mi Ga Valley. Plan envisioned deployment of 1st Bde, 101st Abn Div from Phan Rang o/a D-4 by aircraft/vehicles to Khanh Duong Airfield on Highway 21 approximately 30 kilometers west of Duc My. With Khanh Duong as a base of operations the 1st Bde, 101st Abn Div conducts heliborne assaults into designated AO and conducts search and destroy operations in conjunction with one ARVN battalion and CIDG assets. Operation SUMMERALL began on 30 March 1967 for a period of 45-60 days.

(j) FRAG ORDER 29-67 directed CO, Company B, 5th Special Forces Group to employ CIDG forces to conduct border surveillance along Laotian/RVN border in northwest Kontum Province during the period 4 April 1967 through 31 May 1967. These operations augment and assist Project OMEGA and mobile guerrilla operations along the border.

(k) FRAG ORDER 30-67 (BLACK JACK 25) employed Mobile Guerrilla Force 876 to locate enemy forces, interdict infiltration routes, and destroy enemy forces within capabilities in Dak Akoi area northeast of Kontum City. Operation began 15 April 1967 for a period of approximately 30 days.

(l) FRAG ORDER 31-67 (BUCKNER) employed Project OMEGA to conduct border surveillance vicinity north Plei Trap area. Operation began 15 April 1967 for a period of approximately 30 days.

(m) OPLAN 135-67 (WALTER REED) employed on a contingency basis a battalion from the 4th Inf Div to conduct search and destroy operations in Dak To area, upgrade Route 512 from Dak To to the border, and prepare fire bases to support future operations.

(2) Other Significant Activities.

(a) Defoliation: On 12 Feb 67 a plan was submitted to COMUSMACV and CG, II Corps which would provide for authority to conduct defoliation/crop destruction operations in large areas of II CTZ. Purpose is to facilitate actual operations and reduce reaction time in obtaining approval of specific areas for defoliation/crop destruction.

(b) Combined Campaign Plan for II CTZ (3d and 4th quarter 1967). The present document expires on 30 June 1967, COMUSMACV directed I FFORCEV to prepare a follow-on plan and forward it for approval NLT 1 May 1967. A meeting between the G3s of II Corps, ROKFV, FC and I FFORCEV was held on 11 March 1967 at Pleiku. The G3s agreed to a planning schedule for preparation of plan for the second half of 1967. At the second meeting on 15 April 1967 at Nha Trang, the G3s discussed specific proposals for the conduct of combined operations and goals for each force. Agreement was reached as to the substance of each country's role in operations in II CTZ for the second half of calendar year 1967. Minor corrections and changes were made during the remainder of April with publication of the document beginning on 25 April 1967. Target date for signing the combined plan is o/a 15 May 1967.

(c) Project OREGON: COMUSMACV directed USARV to develop a plan to organize a provisional infantry division prepared to deploy on short notice to I CTZ. USARV published OPLAN OREGON 1-67 on 10 March 1967. On 6 April 1967 MACV ordered Project OREGON implemented.

12

SECRET

17

SECRET

AVFA-GC-OT

SUBJECT: Operational Report for Quarterly Period Ending 30 April 1967, RCS CSFOR-65 (U)

1. I FFORCEV published OPLAN 134-67 (SHAFTER) on 26 March 1967 to notify, marshal and deploy the following units designated for TF OREGON.

- a. Task Force, 3d Bde, 25th Inf Div
- *b. 1st Bde, 101st Abn Div
- c. Troop B, 1st Sqdn, 9th Cav (1st Cav Div) (AM)
- d. 3d Bn, 18th Arty (8"/175) (SP) (-)
- e. Hq & Hq Co, 14th Avn Bn
- f. 161st Assault Helicopter Company
- g. 174th Assault Helicopter Company
- *h. 176th Assault Helicopter Company
- i. 2 Platoons, 167th RR Company
- j. 4 Light Observation Helicopters (4th Inf Div)

2. On 7 - 8 April 1967 the 1st Cav Div (AM) deployed a two battalion brigade to Duc Pho to relieve a marine task force in place. The first battalion (2d Bn, 5th Cav), closed into Duc Pho approximately 20 hours after I FFORCEV received the mission from MACV. Movement of 1st Cav Div (AM) elements to Duc Pho was an interim action to provide lead time to withdraw the 3d Bde, 25th Inf Div from the critical Phu My Valley. One battalion of the 1st Cav Div (AM) was replaced by the 1st Bn, 35th Inf on 15 April 1967. Headquarters 3rd Bde, 25th Inf Div and 2d Bn, 35th Inf replaced remaining 1st Cav Div (AM) units in Duc Pho on 19 April 1967. 1st Bn, 14th Inf deployed to Chu Lai on 15 April and became opcon to 196th Inf Bde.

3. All I FFORCEV units, except those in para 1 marked with an asterisk closed I CTZ prior to 22 April 1967.

4. Upon order of COMUSMACV, Operation SUMMERALL terminated 292400H March 1967 in preparation for deployment of 1st Bde, 101st Abn Div to Task Force OREGON. 1st Bde, 101st Abn Div began deployment by sea to Chu Lai beginning on 1 May 1967 to be completed NLT 5 May 1967.

b. Operational Activities:

(1) FRAG ORDER MSG A-0584, Dtg 250845 Aug 66 (BYRD)

(a) Operation BYRD (Incl 2), which began on 25 Aug 66, continued in Binh Thuan Province with Task Force 2d Bn, 7th Cav, 1st Cav Div (AM) (changed to 2d Bn, 7th Cav on 13 Feb 67, when Co B, 1st Bn, 7th Cav returned to its parent battalion) conducting operations in support of the Revolutionary Development Program (Operation HOP LUC). Operation HOP LUC began on 16 Nov 66 with two battalions of the ARVN 44th Inf Regt and RF/PF forces in the area concentrating their efforts in the triangle area north of Phan Thiet, generally astride Highway 8. The two ARVN battalions have and continue to periodically exchange missions with one conducting Revolutionary Development and tactical training while the other conducts search operations generally with platoon and company size elements operating in joint operations with US Forces.

SECRET

SECRET

18

AVFA-GC-OT

SUBJECT: Operational Report for Quarterly Period Ending 30 April
1967, RCS CSFOR-65 (U)

(b) 2d Bn, 7th Cav activities during February were characterized by numerous company size helicopter assaults and search operations with infrequent contacts and cross training with elements of the 4th Bn, 44th ARVN Regt which also participated in ambush, air assaults and patrol operations. Additionally elements of Task Force 2d Bn, 7th Cav, 4th Bn, 44th ARVN Regt, and RF/PF forces supported the 1st Bde, 101st Abn Div in the GATLING and FARRAGUT AOs. On 2 Feb 67, Company C, 2d Bn, 7th Cav moved to Bao Loc, OPCON 1st Bde, 101st Abn Div and conducted operations in the GATLING I AO with no significant contacts. Task Force 2d Bn, 7th Cav (-) became OPCON 1st Bde, 101st Abn Div with the initiation of GATLING II on 5 Feb 67, remained OPCON to 15 Feb 67, and participated in air assaults with elements of the 1st Bde, 101st Abn Div. The remaining two companies continued operations in support of the Revolutionary Development Program. During TET (8-12 Feb 67), units restricted their activities to intensified local defensive patrolling. After the termination of GATLING II (16 Feb 67), continued operation in the FARRAGUT AO included the participation of one company of the 2d Bn, 7th Cav with 44th ARVN Regt elements and LRRPs from the 1st Bde, 101st Abn Div. Their mission consisted primarily of screening the west and southwest flank of the FARRAGUT AO adjacent to the east flank of the BYRD AO. On 22 Feb 67, all elements of 2d Bn, 7th Cav and 44th ARVN Regt returned to the BYRD AO.

(c) On 19 Feb 67, Co A, 2d Bn, 7th Cav found and destroyed 30 structures vicinity AN 8741 containing miscellaneous military equipment. On 22 Feb 67, 2d Bn, 7th Cav again supported the 1st Bde, 101st Abn Div with 13 aircraft to move units from Song Mao to Di Linh. Company D, 2d Bn, 7th Cav discovered a large enemy campsite vicinity AN 7843 containing numerous documents. On 27 Feb 67 Co B, 2d Bn, 7th Cav discovered another like campsite vicinity ZT 2329, while nearby at ZT 2226 two complete rice mills were discovered with a diesel engine as a power source. Friendly and enemy losses for the month of February were: Friendly - 1 KIA and 11 WIA. Enemy - 18 KIA, 6 PWs and 6 small arms captured.

(d) On 3 March 1967 Co C, 2d Bn, 7th Cav discovered a 60 bed hospital complex with documents and medical supplies vicinity ZT 1832. On the following day Co A, 2d Bn, 7th Cav located and destroyed numerous structures and several bunkers at ZS 2790. Heaviest friendly casualties for the period were sustained on 6 March 1967 when Co A, 2d Bn, 7th Cav had 7 WIA vicinity ZS 2692 from sniper fire, booby traps and punji stakes. On 8 March 1967, B and D Co, 2d Bn, 7th Cav with one ARVN company air assaulted to the northwest part of the AO (Military Region Sixth Headquarters area), but there was no contact. On 9 March 1967, Co D, 2d Bn, 7th Cav discovered and destroyed a camp complex large enough to accommodate 200 persons at AN 7350. The primary effort was in the west and northwest part of the AO to exploit suspected enemy concentrations. The western boundary of the AO was extended on 14 March 1967, but contact in the area was negligible. With the departure of the 1st Bde, 101st Abn Div from Song Mao and the subsequent termination of operation FARRAGUT, the AO was adjusted on 17 March 1967 to include the same general area previously covered prior to the GATLING and FARRAGUT operations. On entering into this eastern extension an increase of significant contacts occurred. On 24 March 1967 Co C, 2d Bn, 7th Cav engaged 12 VC vicinity BN 1320 resulting in 2 friendly WIA, 9 VC KIA, 1 PW and 6 small arms captured. On 28 March 1967 elements of 2d Bn, 7th Cav and one company of the 3d Bn, 44th ARVN Regt moved to Song Mao to continue operations in that area with an initial contact in that day resulting in Friendly: - no casualties; Enemy - 1 VC KIA, 7 PWs and 8 small arms captured. On 29 March 1967 in the same area a platoon of B Co, 2d Bn, 7th Cav in sporadic contacts

SECRET

SECRET

AVFA-GC-OT

SUBJECT: Operational Report for Quarterly Period Ending 30 April
1967, RCS CSFOR-65 (U)

killed 9 more VC with 1 VC PW and 5 small arms captured. On the following day Co B, 2d Bn, 7th Cav supported by ARA, again in sporadic contacts in the same general area had no friendly casualties while enemy losses were: 37 VC KIA, 3 PWs and 8 small arms captured. Total results for March 1967 were: Friendly - 2 KIA and 41 WIA; Enemy - 80 KIA, 21 PWs and 49 small arms captured.

(e) On 2 April 1967 Co B, 2d Bn, 7th Cav in a combined operation with a company from 3d Bn, 44th ARVN Regt engaged a small VC force northwest of Song Mao, killing 4 VC and capturing 2 small arms. Co B, 2d Bn, 7th Cav exchanged missions with Co C, 2d Bn, 7th Cav on 3 April 1967, the former returning to the vicinity of Phan Thiet and the later continuing the combine operation with a company from 3d Bn, 44th ARVN Regt. In the one significant action of the month, on 5 April 1967 Co C, 2d Bn, 7th Cav air assaulted 14 kilometers east of Song Mao in support of a company from 3d Bn, 44th ARVN Regt which had engaged an estimated NVA company occupying well-fortified, dug-in positions. Gunships, ARA and artillery supported the attack of the positions. Both companies extracted by 1940H. Sweep of the area on the following morning revealed that the enemy had vacated the position during the night. On 8 April 1967 Co B, 2d Bn, 7th Cav engaged an estimated 15-20 VC 17 kilometers north of Phan Thiet. Caught in the open, the VC suffered 12 KIA, 1 PW and lost 7 small arms; there were no friendly casualties. In another action the same day Co B, 2d Bn, 7th Cav had contact with 8 VC, killing 6, there were no friendly casualties. On 12 April 1967 Co B, 2d Bn, 7th Cav assaulted two platoons 10 kilometers north of Phan Thiet and had contact with a VC squad size force, resulting in 9 VC KIA, 5 PWs and 7 small arms captured; there were no friendly casualties. During the balance of April contacts dwindled in number and size. Eight more VC were killed in sporadic actions. On 21 April 1967 1st Platoon of B Battery, 4th Bn, 60th Arty (AW) joined and became OPCON to 2d Bn, 7th Cav. Total results for April were: Friendly 3 KIA and 43 WIA; Enemy - 62 KIA, 11 PWs and 36 small arms captured.

(f) Combat losses for this operation date are:

<u>Enemy</u>		<u>Friendly</u>	
KIA	526	KIA	14
Captured	79	WIA	180
Detainees	817		
Small Arms	176		
Crew Served Weapons	1		

(2) OPLAN 49-66 (ADAMS)

(a) Operation ADAMS (Incl 3) began 260001H Oct 66 with the 1st Bde, 4th Inf Div committing three battalions, (1st Bn, 8th Inf, 3d Bn, 8th Inf and 3d Bn, 12th Inf) in east central Phu Yen Province. The operation began as a rice harvest security mission. When the rice harvest ended, the primary mission of the brigade became search and destroy in the AO generally bounded by CQ 1750, BQ 5050, BQ 5095 and CQ 1092. 1st Bn, 8th Inf was withdrawn from the ADAMS AO 260730H Jan 67 and employed in the SAM HOUSTON AO.

(b) There were no major contacts during February; however significant losses were inflicted on the enemy in a series of several contacts. On 9 Feb 67 3d Bn, 8th Inf conducted loud speaker and leaflet operations over the AO and 3d Bn, 12th Inf began distribution of 500 TET packages and 700 cans of soup in the Tuy An District. Refugees the

15
SECRET

SECRET

20

AVFA-GC-OT

SUBJECT: Operational Report for Quarterly Period Ending 30 April
1967, RCS CSFCA-65 (U)

following day amounted to 136. The 1st Bde CP, 3d Bn, 8th Inf and 6th Bn, 29th Arty were withdrawn from ADAMS AO and closed SAM HOUSTON AO, Oasis, at 1730 hours 18 Feb 67. 3d Bn, 12th Inf became I FFORCEV re-serve and designated as Task Force Ivy on 17 Feb 67. Small and scattered contacts with enemy forces continue with 3d Bn, 12th Inf conducting security missions for the 39th Engineers along Route 21 and search and clear operations with 4th Bn, 47th ARVN Regt during February.

(c) On 9 March 1967, in the vicinity of Hill 86 located at CQ 0376 at 0013 hours a platoon from Co A, 3d Bn, 12th Inf was attacked by a 100 man VC force. Heavy casualties were inflicted on the platoon before relief elements arrived. Total casualties for this action were: Friendly - 12 KIA, 26 WIA, 19 small arms and crew served weapons lost. Enemy - 5 VC KIA. In the days following this action the 3d Bn, 12th Inf had a series of small actions in the vicinity of Hill 86 resulting in 47 VC KIA. Personal belonging of US personnel killed on Hill 86 were found on VC bodies, identifying them as the same force that attacked Hill 86. Sporadic contacts continued throughout the remainder of March accounting for a significant number of enemy casualties inflicted by Task Force Ivy (3d Bn, 12th Inf and 2d Bn, 327th Inf). The 2d Bn, 327th Inf was OPCON to Task Force Ivy from 14-25 March 1967 and returned to OPCON to 1st Bde, 101st Abn Div to participate in operation SUMMERALL. The 3d Bn, 12th Inf was extracted from the AO on 2 April 1967, and Operation ADAMS was terminated at 022400H April 1967.

(d) Combat losses for the operation were:

<u>Enemy</u>		<u>Friendly</u>	
KIA	491	KIA	46
Captured	146	WIA	491
Detainees	33		
Small Arms	160		
Crew Served Weapons	1		

(3) OPLAN 42-66 (THAYER II)

(a) Operation THAYER II (Incl 4) which began on 25 Oct 66 continued in Binh Dinh Province. The 1st Cav Div (AM) major areas of operations continued to be the OREGON TRAIL Area. No major contact was reported during the first five days of February, however, a 300 bunker complex was located vicinity BR 6765 by elements of 2d Bn, 5th Cav.

(b) Just prior to the TET stand down a mortar attack was conducted by enemy forces on English Airfield. On the morning of the 6th nearly 100 rounds were received, killing 1 US and wounding 56; four helicopters were also damaged. A major attack may have been prevented by an engagement by the 3d Bn, 40th ARVN Regt with an estimated NVA battalion east of Bong Son. Heavy contact from 1400 to 1500 hours on the 6 Feb resulted in 81 enemy KIA. Following the TET stand down from 8-12 Feb 67, operation THAYER II ended and on 12 Feb 67, the 1st Cav Div (AM) initiated operation PERSHING.

(c) Combat losses for the operation were:

<u>Enemy</u>		<u>Friendly</u>	
KIA	1,757	KIA	204
Captured	151	WIA	876
Detainees	2,123		
Small Arms Captured	426		
Crew Served Weapons	53		

16

SECRET

SECRET

AVFA-GC-OT

SUBJECT: Operational Report for Quarterly Period Ending 30 April
1967, RCS CSFOR-65 (U)

(4) FRAG ORDER MSG A-0554, Dtg 110315 Feb 67 (PERSHING)

(a) Operation PERSHING (Incl 4) began on 12 Feb 67. This operation was designed to locate and destroy NVA and VC forces in northern Binh Dinh Province. The 1st Cav Div (AM) initially employed one brigade (two battalions) in the vicinity of Tam Quan to search to the south. Blocking positions were established in the vicinity of Bong Song Bridge by the third organic brigade (one battalion) and along the northern bank of the Lai Giang River by two battalions of the 40th ARVN Regt. Task Force 3d Bde, 25th Inf Div OPCON to the division screened along the southern portion of the AO (Suoi Ca Valley - Crescent Nieu Mu Mountains) to protect ARVN 41st Regt engaged in support of Revolutionary Development Program in the Phu My Valley. Two sharp contacts were fought with battalion size elements of the 22d NVA Regt. On 13 Feb 67 the 1st and 2d Bns, 5th Cav engaged a battalion of the 22d NVA Regt in the coastal plains northeast of Bong Son. On 18 Feb 67, 5th Bn, 8th Cav supported by 1st Bn, 8th Cav engaged another battalion of the 22d NVA Regt in the high ground west of Bong Son Plains. Following these actions, the enemy had fragmented his forces and action consisted of digging him out of tunnel and bunker complexes north of Bong Son. Action was expanded to include the An Lao Valley with an additional battalion being added to the 3d Brigade for this purpose. Several small unit actions occurred in the southern end of the valley. Light contact was reported by 3d Bde, 25th Inf in the Suoi Ca Valley and a fortified complex of 571 bunkers was destroyed in the high ground to the west.

(b) The 1st Brigade had only light contact in the Bong Son Plains until the evening of 19 March 1967 when Co A, 1st Bn, 8th Cav made contact with an estimated enemy battalion at BS 8716. Other units of the 1st Bn, 8th Cav and 2d Bn, 8th Cav reinforced and the 2d Bn, 12th Cav passed from OPCON 3d Brigade to OPCON 1st Brigade as the situation developed. On 20 March while sweeping to the south from vicinity of the previous contact Co B, 1st Bn, 8th Cav engaged an estimated enemy battalion. 1st Bn, 5th Cav was passed from OPCON 2d Brigade to OPCON 1st Brigade and air assaulted to the area and the task organization was again reorganized with the 1st Brigade now consisting of the 1st Bn, 8th Cav (-), 2d Bn, 8th Cav and 2d Bn, 12th Cav. The 2d Brigade, with 1st Bn, 5th Cav, 2d Bn, 5th Cav and Co B, 1st Bn, 8th Cav continued to develop the southern contact vicinity BS 8604. Contact with enemy forces continued sporadically until 2200 hours, 21 March 1967 when contact with major forces was lost. Results of this engagement were: US 34 KIA, enemy 159 KIA.

(c) The 2d Brigade, prior to its action on the Bong Son Plains had fought two sharp engagements with reinforced companies from the 18th NVA Regt in the Crescent area. On 16 March 1967, following an initial contact by C Co, 1st Bn, 9th Cav, two companies of the 2d Bn, 5th Cav air assaulted to the southern edge of the Cay Giap Mountains vicinity BR 9788. 1st Bn, 35th Inf from Task Force 3d Bn, 25th Inf was also assaulted to the area. Contact was lost on 7 March 1967. Result of this action were: Friendly - 10 KIA and 20 WIA; Enemy - 82 NVA KIA and 2 PWs. On 11 March 1967 Co C, 2d Bn, 5th Cav while air assaulting to the south of the Dam Tra O Lake was pinned down by an estimated enemy company vicinity BR 9780. Two additional companies reinforced. Contact lasted from 1120 to 1920 hours resulting in 19 US KIA, 25 WIA and 10 enemy KIA.

(d) 3d Brigade continued screening operations west of Bong Son until 18 March 1967, when 1st Bn, 7th Cav was employed to sweep the high ground and cover the flanks of a two battalion Vietnamese Marine Task Force conducting clearing operations in the An Lao valley. On 27 March 1967 5th Bn, 7th Cav assaulted to the northern end of the valley to screen in support of this search. No significant contact was made.

SECRET¹⁷

SECRET

022

AVFA-GC-OT

SUBJECT: Operational Report for Quarterly Period Ending 30 April
1967, RCS CSFOR-65 (U)

(e) Task Force 3d Bde, 25th Inf Div screened the southern portion of the PERSHING AO, concentrating in the Suoi Ca Valley, the Highway 506 Valley and the western Crescent. In addition to reinforcing the 2d Brigade in the eastern Crescent, the Task Force employed the 1st Bn, 14th Inf in support of the ARVN 41st Regt in the Phu My Valley following a contact with the 7th Bn, 18th NVA Regt vicinity BR 9363 on 26 March 1967. On 27 March 1967 elements of the 1st Bn, 14th Inf killed 11 VC in the southern Nieu Mu Mountains. Two US were WIA in this action. In addition to RVN Marine Task Force operating in the An Lao Valley, the ARVN 40th and 41st Regt continued operations in Binh Dinh Province in conjunction with the 1st Cav Div (AM). The 40th ARVN Regt employed two battalions north of Bong Son and two battalions on Highway 1 in the Crescent. These battalions also conducted search and destroy missions in the eastern Crescent. The 41st ARVN Regt continued search and destroy missions in the Phu My Valley in support of Revolutionary Development. In two major engagements with elements of the 18th NVA Regt, on 26 March losses were: Friendly - 34 KIA and 54 WIA; Enemy - 51 KIA, 3 PWs and 16 small arms captured.

(f) The 1st Cav Div (AM) also conducted operation LEJEUNE in southern Quang Ngai Province, employing its own 2d Bde and 3rd Bde, 25th Inf during the period 7-22 April 1967. With the termination of LEJEUNE, the division lost OPCON of the 3d Bde, 25th Inf which had operated with it in Binh Dinh Province since 3 Jan 67.

(g) The 1st Brigade employing from two to three battalions and a tank company (-) throughout April 1967, operated in the Bong Son Plains. In contrast with previous months, no contact was made with battalion size forces of the 22d NVA Regt, however there were daily contacts with small groups of VC and NVA in the hamlets between English Airfield and Tam Quan. Departure of the 2d Brigade from the Bong Son area for operation LEJEUNE required the brigade to assume added responsibility for security of logistical installations.

(h) The 2d Brigade operated in the Bong Son Plains until 7 April 1967 when it began movement to the I Corps Zone. Upon return to the AO on 22 April 1967, the brigade employed two battalions (1st Bn, 5th Cav and 2d Bn, 5th Cav) in the Suoi Ca, and Highway 506 areas assuming responsibility for the area vacated by the 3d Brigade, 25th Inf. Only light contact with local VC was made during these operations which were conducted in conjunction with the 40th and 41st ARVN Regiments.

(i) The 3d Brigade concentrated its effort in the An Lao Valley throughout April 1967. This area produced the heaviest contact recorded during the month when on 8 April 1967, elements of the 1st Bn, 7th Cav and 5th Bn, 7th Cav made contact with an entrenched enemy company at BS 7104 at 1250 hours. Fighting continued throughout the afternoon and into the evening. Losses for this action were: Friendly - 23 KIA and 28 WIA; Enemy - 63 KIA and 4 PWs. No other major fights occurred in the An Lao, but sporadic enemy resistance was encountered daily.

(j) Despite the lack of major actions in the PERSHING AO during April 1967, US Forces continued to inflict heavy losses on the enemy. US casualties were also relatively high as a result of numerous mines and booby traps and snipers encountered in the fortified hamlets on the Bong Son Plains.

SECRET

SECRET

AVFA-GC-OT

SUBJECT: Operational Report for Quarterly Period Ending 30 April
1967, RCS CSFOR-65 (U)

(k) Combat losses of this operation to date:

<u>Enemy</u>		<u>Friendly</u>	
KIA	1,286	KIA	254
Captured	1,221	WIA	1,001
Detainees	4,923		
Small Arms	298		
Crew Served Weapons	13		

(5) OPLAN 19-66 (SAM HOUSTON)

(a) Operation SAM HOUSTON (Incl 5) began on 1 Jan 67 as a continuation of border surveillance with the 4th Inf Div employing five battalions in the AO, with one battalion of the 3d Bde, 25th Inf OPCON within the AO. The mission of the 4th Inf Div was to reconnoiter and maintain surveillance of the Cambodian border, conduct ambushes and block enemy penetration into assigned AO.

(b) Sharp contacts with NVA forces began along the border area on 15 Feb 67. At 0712 hours on the 15 Feb 67, Co A, 1st Bn, 22d Inf while engaged in patrolling around the perimeter, encountered heavy small arms fire from an estimated enemy company. Friendly air and artillery were called in resulting in 35 enemy KIA. On 16 Feb 67 a series of heavy contacts between Co C, 2d Bn, 8th Inf/ Co B, 1st Bn, 12th Inf/ Co A, B and C, 1st Bn, 22 Inf with NVA elements west of the Se San River resulted in a two day total of: Friendly - 30 KIA and 40 WIA; Enemy - 112 KIA, 4 NVA PWs and 43 small arms captured. Co A and C of 1st Bn, 12th Inf engaged a unknown size force vicinity YA 5954 on 25 Feb 67. Six immediate air strikes were called in the area of contact. Results: Friendly - 1 KIA and 28 WIA; Enemy - 49 NVA KIA. During February the 4th Inf Div continued to occupy blocking positions along the Nam Sathay River. Four LRRP's were employed west of the river to assist in surveillance of the border area.

(c) From 12-23 March 1967 a series of heavy contacts with NVA forces and mortar attacks on base camps in the western portion of the AO highlighted the month activities. On 12 March 1967 Co A, 2d Bn, 35th Inf engaged an estimated NVA battalion vicinity YA 6649. The enemy withdrew to the west and was supported by mortar fire from the west side of the Cambodian border. Results: 19 US KIA and 69 WIA; Enemy - 53 NVA KIA. On 12 March 1967 fire support base of 1st Bn, 22d Inf in vicinity YA 6160 received 30 rounds of 82mm mortar fires resulting in 14 US WIA. On 14 March 1967 the 2d Brigade CP vicinity YA 8545 received ten mortar attacks resulting in 45 US WIA. The same day Co A and C, 1st Bn, 22d Inf engaged an unknown size force vicinity YA 6058 resulting in 17 US KIA and 26 WIA; Enemy losses were 53 NVA KIA. On 16 March 1967 the CP of 1st Bn, 12th Inf in vicinity YA 7538 received 60 rounds of 82mm mortar resulting in 10 US WIA. On 22 March 1967 Co A and B, 1st Bn, 8th Inf had heavy contact with an estimated NVA Battalion at YA 6824 which lasted throughout the day. Results: 25 US KIA and 39 WIA. Police of the battlefield the following day uncovered 136 NVA bodies.

(d) During the period 1-5 April 1967, the 4th Inf Div (-) continued border surveillance operations with six maneuver battalions. There were no significant contact during the period. Operation SAM HOUSTON terminated at 052400H April 1967.

(e) Combat losses for the operation were:

<u>Enemy</u>		<u>Friendly</u>	
KIA	733	KIA	172
Captured	17	WIA	767
Detainees	288		
Small Arms	162		
Crew Served Weapons	47		

19
SECRET

SECRET

24

AVFA-GC-OT

SUBJECT: Operational Report for Quarterly Period Ending 30 April 1967, RCS CSFOR-65 (U)

(6) OPLAN 42-66 (FRANCIS MARION)

(a) Operation FRANCIS MARION (Incl 5) began at 06001H April 1967, as a continuation of Operation SAM HOUSTON with the same AO and the 4th Inf Div conducting surveillance on western highlands with six battalions. In response to intelligence reports of increased enemy action in the Polie Kleng area one battalion Task Force 1st Bn, 12th Inf was moved by air and overland beginning 9 April 1967 and closing at Polie Kleng on 12 April 1967. On 18 April 1967 Task Force 1st Bn, 12th Inf moved to Oasis in a general reorientation of troop deployment to west and northwest of Oasis area (ZA 1129). On 17 April 1967 one platoon from Co C, 2d Bn, 8th Inf and a CIDG element from Plei Me engaged an estimated NVA Company from 1035H vicinity ZA 1317. TAC air supported with following results: Friendly - 9 KIA and 20 WIA; Enemy - 7 KIA. Task Force 3d Bn, 8th Inf moved from Dragon Mountain on 26 April 1967 to Buon Blech in response to suspected build up of enemy forces in north eastern Darlac, southern Phu Bon area. The 4th Inf Div reacting from increased enemy activity between Duc Co and Chu Pong Mountain moved the 1st Bn, 8th Inf into the area on 26 April 1967 while the 1st Bn, 12th Inf operated between Chu Pong mountains and Oasis.

(b) Combat losses for this operation to date:

	<u>Enemy</u>		<u>Friendly</u>
KIA	64	KIA	17
Captured	10	WIA	103
Detainees	150		
Small Arms	38		
Crew Served Weapons	2		

(7) FRAG ORDER 2-67 (FARRAGUT)

(a) Operation FARRAGUT (Incl 2) began in the southern portion of II CTZ on 26 Jan 67. Mission for the operation was to locate and destroy enemy within secret base 35.

(b) From 3 Feb 67 to 7 Feb 67, 2d Bn, 327th Inf had light contact at scattered locations in the secret base area. Contact resulted in 1 friendly WIA. Enemy losses were 10 VC KIA, 2 VC PW and 6 small arms captured. During the TET truce period (8-12 Feb 67) a defensive patrol located an enemy supply cache which included a generator, radio receiver, short wave radio, and miscellaneous communications and medical supplies (BN 5477). The 2d Bn, 327th Inf shifted southeast to Highway 1, vicinity BN 6057 on 12 Feb 67. From 12 to 14 Feb 67, the battalion cleared and opened Highway 1 from vicinity BN 6057 to the village of Vinh Hoa (BN 5551). On 16 Feb 67, the 2d Bn, 327th Inf was heli lifted to Song Mao (BN 2844).

(c) A B-52 strike was made on the Le Hong Phong Base Area (Center of Mass vicinity BN 0831) on 17 Feb 67. To exploit this strike, 1st Bde, 101st Abn Div employed three battalions. 2d Bn, 327th Inf heli assaulted into positions to the south and east of the strike. 2d Bn, 502d Inf and 1st Bn, 327th Inf assaulted on the north and west of the strike and moved toward the blocking positions of 2d Bn, 327th Inf. Light and sporadic contact was encountered through 22 Feb 67.

(d) On 23 Feb 67 2d Bn, 502d Inf was extracted to Song Mao. Reacting to VC attack on ARVN forces in vicinity of Di Linh (AN 8181), 2d Bn, 502d Inf air assaulted to the area in the afternoon of 24 Feb 67.

SECRET

25

SECRET

AVFA-GC-OT

SUBJECT: Operational Report for Quarterly Period Ending 30 April 1967, RCS CSFOR-65 (U)

There was no contact initially. Co B, 2d Bn, 502d Inf made an air assault vicinity AN 7574, southwest of Di Linh, on 25 Feb 67 and had a sharp contact. Results: Friendly - 1 KIA and 8 WIA; Enemy - 3 VC KIA and 4 small arms captured. No further significant contact was made in the vicinity of Di Linh.

(e) On 27 Feb 67, 2d Bn, 502d Inf was heli lifted to Song Mao. 1st Bn, 327th Inf moved from Le Hong Phong area by air and overland to Song Mao. The 1st Bde, 101st Abn Div (-) closed Song Mao on 27 Feb 67. The brigade prepared for future operations in FARRAGUT AO on 28 Feb 67.

(f) On 1 March 1967 at 1400H 2d Bn, 327th Inf (-), acting on intelligence from a returnee that a VC company was in the vicinity of Tuy Phong, air assaulted into LZ vicinity BN 4145. 2d Bn, 327th Inf (-) searched the area and returned to Song Mao on 2 March 1967. Results were 4 VC KIA and 2 small arms captured. On 1-2 March 1967 the remainder of the 1st Bde, 101st Abn Div continued preparation at Song Mao for future operation. On 3 March 1967, 1st Bn, 327th Inf air assaulted into LZ vicinity BN 2254 to conduct search operations in the area, while 2d Bn, 327th Inf secured Highway 1 to the east. During the period 3-8 March 1967 there was light and scattered contact with small enemy units.

(g) On 9 March 1967 operations began in the area of Secret Base 35 (SB 35). 2d Bn, 502d Inf air assaulted into LZ vicinity Song Hoi, with the mission to search on multiple axes to the west. 1st Bn, 327th Inf assaulted into the center of SB 35 and conducted search on multiple axes to the south. 2d Bn, 327th Inf air assaulted into LZs to block enemy egress to the west. The brigade CP moved from Phan Thiet to Phan Rang. During the operation in SB 35 from 9-13 March 1967, there was light and sporadic contact. On 13 March 1967 the 2d Bn, 327th Inf terminated search and destroy mission in SB 35 and prepared for movement to ADAMS AO, to reinforce operations in Phu Yen Province. The 2d Bn, 327th Inf arrived in Tuy Hoa on 14 March and became OPCON to Task Force IVY.

(h) On 14-15 March 1967, 1st Bde, 101st Abn Div continued operations in SB 35 with two battalions with light contact. On 16 March the 2d Bn, 502d Inf (-) began search of SB 7 and along Highway 1 while 1st Bn, 327th Inf continued search of SB 35. On 19 March Co B, 2d Bn, 502d Inf air assaulted to SB 7, joining the remainder of the battalion. Both battalions continued operation in SBs 7 and 35 with light contact. On 22 March the 1st Bn, 327th Inf moved to Phang Rang and on 23 March the 2d Bn, 502d Inf closed Phang Rang. Operation FARRAGUT ended 232400H March 1967.

(i) Combat losses for this operation are:

<u>Enemy</u>		<u>Friendly</u>	
KIA	115	KIA	14
Captured	20	WIA	128
Detainees	139		
Small Arms	80		

(8) FRAG ORDER 7-67 and 9-67 (GATLING I & II)

(a) Operation GATLING began on 1 Feb 67 with 1st Bde, 101st Abn Div making a surprise raid within operation FARRAGUT designated operation GATLING I.

(b) The operation was designed to discover and disrupt a meeting of military and political leaders of Military Region 6. Following a B-52 strike vicinity YT 9986 on 1 Feb 67, 1st Bn, 327th Inf and 2d Bn, 502d Inf were heli assaulted into the area. 1st Bde, 101st Abn Div

SECRET

SECRET

26

AVFA-GC-OT

SUBJECT: Operational Report for Quarterly Period Ending 30 April
1967, RCS CSFOR-65 (U)

with Command Post at Bao Loc (ZT 0375) was given OPCON 2d Bn, 7th Cav located in southern Binh Thuan Province. One company of 2d Bn, 7th Cav supported the brigade in the GATLING I and II operations. CIDG and Mike forces also supported. Between 1 and 4 Feb 67, GATLING I did not produce significant results.

(c) On 4 Feb 67, 1st Bn, 327th Inf and 2d Bn, 502d Inf moved to Bao Lac and prepared for GATLING II. At 0704H on 5 Feb 67, B-52 strikes were made at ZT 7339 and AN 2346, the suspected area of Headquarters Military Region 6. 2d Bn, 502d Inf reinforced by 2d Bn, 7th Cav (-) heli assaulted into the area to exploit the strike and search for enemy installations. 1st Bn, 327th Inf followed 2d Bn, 502d Inf into the area from Bao Lac, heli assaulting at 1145 hours 6 Feb 67. 1st Bn, 327th Inf had minor contact with a small group of VC vicinity ZT 2247. Results: 4 VC KIA and 2 small arms captured. On 7 Feb 67 Co C, 1st Bn, 327th Inf found an enemy camp vicinity ZT 7451 composed of over 100 structures, a mess hall, and officers quarters. The camp had been used in January 1967. Co B, 2d Bn, 502d Inf located a VC PW camp on 10 Feb 67. There were 11 male and 2 female prisoners of the VC found in the camp. Elements of the two battalions and the 2d Bn, 7th Cav found a series of caches which contained communication equipment during the period 12 to 15 Feb 67. On 15 Feb 67, 1st Bde, 101st Abn Div units extracted to Phan Thiet and terminated GATLING II.

(d) Results of GATLING I and II:

<u>Enemy</u>		<u>Friendly</u>	
KIA	25	KIA	1
Captured	9	WIA	18
Detainees	32		
Small Arms Captured	17		

(9) OPLAN 205-67 (SUMMERALL)

(a) Operation SUMMERALL (Incl 6) began 30 March 1967 to locate and destroy enemy elements in Haroi area in northern Khanh Hoa and southern Phu Yen Province. Prior to the beginning of the operation the 1st Bde, 101st Abn Div moved overland from Tuy Hoa and by air from Phan Rang to Khanh Duong vicinity BQ 5805. On 30 March 1967 operation began with heli assaults by 2d Bn, 327th Inf to exploit an ARC LIGHT strike vicinity BQ 8317. While searching the area Co B, 2d Bn, 327th Inf captured 1 NVA PW from 9th Bn, 18B Regt.

(b) On 3 April 1967 1st Bn, 327th Inf with one CIDG company and 2d Bn, 502d Inf with one CIDG company conducted air assaults into southwest portion of the AO, vicinity BP 3680 and BP 5588, and began search and destroy operations in zone on multiple axes. The mission of this operation was to search out and destroy the NVA 18B Regt which had been reported in the area. During the period 3-5 April 1967 there was light contact with enemy units resulting in 1 US WIA and 11 VC KIA. On 5 April 1967 the AO was adjusted to include the area bounded by BP 5870, south to BP 5865, east to BP 7465, north to BP 7485 and west to BP 7085. On 6 April 2d Bn, 327th Inf conducted air assaults in southeast portion of the AO vicinity BP 6677. On 9 April the AO was further extended to permit the brigade to search for the NVA 18B Regt. During the period 6-15 April 1967 there was light and sporadic contact with small size enemy forces.

(c) On 15 April 1967, 2d Bn, 502d Inf returned to Khanh Duong to prepare for future operations in the AO. On 17 April 2d Bn, 502d Inf heli assaulted to the Hon Ba area, vicinity BP 8577, to search for the 18B NVA Regt. During the period 17-21 April 1967 no significant contact

22

SECRET

SECRET

AVFA-GC-OT

SUBJECT: Operational Report for Quarterly Period Ending 30 April
1967, RCS CSFOR-65 (U)

with this enemy unit was reported. On 22 April Co B, 2d Bn, 327th Inf made sporadic contact with an unknown size force resulting in 5 US KIA, 4 WIA, 6 VC KIA and 7 small arms captured. On 26 April 1st Bn, 327th Inf extracted to Khanh Duong to prepare for future operations, while the brigade (-) continued operations in the AO. Operation SUMMERALL terminated at 292400H April, with the 2d Bn, 327th Inf and 2d Bn, 502d Inf returning to Khanh Duong on 30 April 1967, closing at 1935H.

(d) Combat losses for the operation were:

<u>Enemy</u>		<u>Friendly</u>	
KIA	70	KIA	7
Captured	12	WIA	50
Small Arms	57		

(1c) FRAG ORDER 34-67, MSG A-1231 (LEJEUNE)

(a) Operation LEJEUNE (Incl 7) began on 7 April 1967 in response to COMUSMACV directive that a brigade from I FFORCEV replace the 3d Bn, 7th Marines at Duc Pho and assume responsibility for the Ba To and Duc Pho Districts in I Corps. 2d Bn, 5th Cav began movement at 1300H to English Airfield and closed at 1700H the same day. On 8 April 2d Bde, 1st Cav Div (AM) and 1st Bn, 5th Cav moved to Duc Pho. Aggressive patrolling to secure the base area was begun immediately and light contact was made with small groups of local VC. Supporting engineers began construction of a C-123 airfield to permit resupply of the brigade, the airfield became operational by 12 April. Additionally, engineers began improvement of roads between Duc Pho and the coast to permit movement of equipment landed over the beach by LST's. Major combat elements of the Marine Battalion departed Duc Pho on 9 April, although a small rear detachment remained to out-load heavy equipment. On 9 April, elements of the 2d Bde reported first blood in operation LEJEUNE, killing 9 VC and capturing 5 PW's and 1 individual weapon at a loss of 2 US WIA. On 10 April, a contact with an estimated enemy platoon at BS 8733 by Co A, 2d Bn, 5th Cav produced the first US KIA of the operation, with 8 additional troopers wounded. Company D, 1st Bn, 5th Cav reinforced with air and artillery supporting. Enemy losses were 8 KIA and 1 small arm captured.

(b) On 15 April 1967, rotation of the 3d Bde, 25th Inf Div to replace the 2d Bde, 1st Cav Div (AM) began. The 2d Bn, 35th Inf replaced the 1st Bn, 5th Cav in the AO closing at 1430H. On the same day, 1st Bn, 14th Inf began movement to Chu Lai, OPCON 196th Inf Bde upon closure at 160200H April. Both these moves were part of the initial movement of Army troops to I Corps in Project OREGON. On 16 April, the heaviest contact of operation LEJEUNE took place north of Duc Pho. Following enemy sightings by scout helicopters, Troop B, 1st Sqdn, 9th Cav air assaulted its aero-rifle platoon to gain contact. Two companies from the 2d Bn, 35th Inf air assaulted to support and in the day's action 45 VC were killed, 18 PWs and 5 small arms captured. US losses were 7 KIA and 7 WIA. On 17 April, the 39th Engr Bn closed at Duc Pho to construct a C-130 airfield and continue improvement of beach sites and roads in the area. On 19 April, rotation of the brigades in the area was completed with the 3d Bde, 25th Inf assuming control of the operation at 1200H. The 2d Bde, 1st Cav Div (AM) and the 2d Bn, 5th Cav returned to Operation PERSHING. Sixteen more VC were killed on the day this movement took place.

(c) On 20 April, Co A, 1st Bn, 35th Inf engaged an estimated 50 man VC force in a bunker complex at BS 8242. Twelve enemy were killed in this action, in addition 7 PWs, 1 small arms and 1 crew served weapon was

SECRET

SECRET

28

AVFA-GC-OT

SUBJECT: Operational Report for Quarterly Period Ending 30 April 1967, RCS CSFOR-65 (U)

captured; there were 3 US WIA. Troop B, 1st Sqdn, 9th Cav accounted for 12 more enemy KIA with armed helicopter fire. On 21 April Troop C, 3d Sqdn, 4th Cav arrived to complete the 3d Bde's maneuver strength and at 221200H April, control of the brigade passed to III MAF, ending operation LEJEUNE.

(d) Combat losses for the operation were:

<u>Enemy</u>		<u>Friendly</u>	
KIA	181	KIA	17
Captured	157	WIA	65
Small Arms	15		
Crew Served Weapons	1		

c. G-3 Air Operations:

(1) The number of sorties flown daily varied from 4 to 105 with a mean of 61.4 sorties per day for the reporting period. The most frequent missions were:

- (a) Direct support of friendly forces in contact.
- (b) Preparation fires on landing zones and objective areas.
- (c) Harassment and interdiction of enemy base areas, assembly areas and infiltration routes.
- (d) Night illumination and strikes.
- (e) Landing zone construction.

(2) During the period approximately 28% of the missions flown for I FFORCEV were COMBAT SKYSPOT.

(3) During February XM-27 (GRAVEL) mine missions were flown for the first time in II Corps. These mines were dispensed by A1F aircraft primarily along known trails and infiltration routes used by VC/NVA. One mission was flown in conjunction with an ARC LIGHT covering a likely egress route. Missions were flown in support of operations PERSHING and SAM HOUSTON. A total of seven (7) missions were flown, each experiencing problems with the dispenser system. As a result of this malfunction and sterilization problem, MACV suspended use of system until further notice.

(4) There were 5484 Tactical Sorties flown in support of major operations during the period indicated.

<u>OPERATION</u>	<u>TOTAL STRIKES</u>	<u>SORTIES/DAY</u>	<u>REMARKS</u>
ADAMS	35	0.57	
BYRD	387	4.3	2 secondary explosions, one secondary fire, 13 bunkers destroyed
BUCKNER	5		
DAZZLEH	466	4.2	12 secondary explosions, four KIA, 12 KIA (Est), 22 bunkers destroyed

24

SECRET

29

CONFIDENTIAL

AVFA-GC-OT
SUBJECT: Operational Report for Quarterly Period Ending 30 April
1967, RCS CSFOR-65 (U)

<u>OPERATION</u>	<u>TOTAL STRIKES</u>	<u>SORTIES DAY</u>	<u>REMARKS</u>
DAWES	6		
FARRAGUT	41	0.8	Three secondary fires, 16 bunkers destroyed
KNOX	104	3.3	Four secondary fires, 1 gun emplacement destroyed 4 bunkers destroyed
LEJEUNE	193	8.0	Five secondary fires, 3 tunnel complexes destroyed, 11 bunkers destroyed
PERSHING	1851	20.9	Numerous secondary explosions and fires, 27 KIA, 21 KIA (Est) 134 bunkers destroyed, 3 AA weapon position destroyed
SAM HOUSTON	1602	25.0	35 secondary explosions, 5 secondary fires, 6 AW weapons positions destroyed, numerous bunkers destroyed
SUMMERALL	75	2.5	
FRANCIS MARION	719	29.0	Four KIA (Est)

(5) B-52 Support.

(a) There were 432 B-52 sorties flown this quarter compared with 489 last quarter in support of ground operations and on suspected enemy concentrations.

(b) During the month of February 1967, 32 missions (234 sorties) were flown. This represents the largest number of missions and sorties flown in support of I FFORCEV during any one month period since the B-52 program was initiated.

<u>DATE</u>	<u>NAME</u>	<u>CODE NAME</u>	<u>SORTIES</u>	<u>OPERATIONS</u>
010030Z Feb	LAMB DONG 7	C-68	15	GATLING I
020610Z Feb	BINH DINH 99	C-72	9	THAYER II
030700Z Feb	BINH DINH 26	None	12	THAYER II
042304Z Feb	BINH TUY 18	D-4	9	GATLING II
042304Z Feb	BINH TUY 19	D-70	9	GATLING II
060700Z Feb	KONTUM 159	D-1	6	SAM HOUSTON
062015Z Feb	BINH DINH 107	D-52	9	DAZZLEM
062130Z Feb	KONTUM 160	D-35	6	SAM HOUSTON
072015Z Feb	BINH DINH 100	D-30	12	THAYER

CONFIDENTIAL

30

AVFA-GC-OT

SUBJECT: Operational Report for Quarterly Period Ending 30 April
1967, RCS CSFOR-67 (U)

<u>DATE</u>	<u>NAME</u>	<u>CODE NAME</u>	<u>SORTIES</u>	<u>OPERATIONS</u>
112300Z Feb	QUANG NGAI 201	G-24	12	PERSHING
131800Z Feb	KONTUM 154		9	DO XA
152300Z Feb	KONTUM 161	D-100	3	SAM HOUSTON
152000Z Feb	KONTUM 162	D-23	3	SAM HOUSTON
152045Z Feb	KONTUM 163	D-12	3	SAM HOUSTON
161215Z Feb	KONTUM 100	D-84	6	SAM HOUSTON
161215Z Feb	KONTUM 201	D-37	6	SAM HOUSTON
170055Z Feb	BINH DINH 201	D-39	6	PERSHING
170150Z Feb	BINH THUAN 8	D-47	9	FARRAGUT
171045Z Feb	KONTUM 203	D-73	6	SAM HOUSTON
171130Z Feb	KONTUM 202	D-63	6	SAM HOUSTON
180600Z Feb	KONTUM 204	D-99	6	SAM HOUSTON
182400Z Feb	BINH DINH 104	D-88	6	PERSHING
192145Z Feb	KONTUM 206	D-83	3	SAM HOUSTON
192145Z Feb	KONTUM 205	D-4	6	SAM HOUSTON
210600Z Feb	BINH DINH 25	None	9	PERSHING
220840Z Feb	KONTUM 207	D-54	6	SAM HOUSTON
230030Z Feb	BINH DINH 73	D-94	6	PERSHING
240010Z Feb	KONTUM 166	D-21	6	SAM HOUSTON
241900Z Feb	KONTUM 168	D-83	6	SAM HOUSTON
260200Z Feb	BINH DINH 112	D-74	9	PERSHING
262045Z Feb	KONTUM 174	D-25	6	SAM HOUSTON
280300Z Feb	BINH DINH 114	E-81	9	PERSHING
282200Z Feb	KONTUM 175	E-39	9	SAM HOUSTON
012100Z March	BINH DINH 119	E-43	9	DAZZLEM
022300Z March	KONTUM 176	E-29	9	SAM HOUSTON
031230Z March	KONTUM 172	E-100	9	DO XA
032200Z March	BINH DINH 120	E-34	6	PERSHING
072400Z March	QUICK RUN 36	E-14	6	PERSHING
082230Z March	KONTUM 180	E-15	9	SAM HOUSTON

26

CONFIDENTIAL

CONFIDENTIAL

AVFA-GC-OT

SUBJECT: Operational Report for Quarterly Period Ending 30 April
1967, RCS CSFOR-65 (U)

090100Z March	BINH DINH 121	E-63	9	PERSHING
092130Z March	KONTUM 179	E-48	9	SAM HOUSTON
110030Z March	KONTUM 181	E-11	6	SAM HOUSTON
120430Z March	BINH DINH 122	E-51	6	PERSHING
162430Z March	QUANG NGAI 322	E-9	9	PERSHING
181700Z March	PHU YEN 39		6	Divert from outside II Corps Area-HAROI
201634Z March	PHU YEN 39		6	Same as above
221800Z March	KONTUM 188	F-26	6	SAM HOUSTON
242130Z March	PLEIKU 129	F-31	6	SAM HOUSTON
261954Z March	BINH DINH 132	F-89	6	PERSHING
280530Z March	KONTUM 183	F-44	6	SAM HOUSTON
282145Z March	KONTUM 184	F-52	6	SAM HOUSTON
300100Z March	PHU YEN 43	F-12	9	SUMMERALL
302130Z March	KONTUM 190	F-58	6	SAM HOUSTON
012130Z April	KONTUM 194	F-37	6	SAM HOUSTON
122155Z April	BINH DINH 135	G-42	6	PERSHING
151200Z April	KONTUM 135	F-50	6	MSQ Alt (DO XA)
232000Z April	PHU YEN 47	G-85	6	KY LO Valley
272300Z April	PHU BON 6	G-54	3	II CORPS
282100Z April	QUANG NGAI 439	H-85	9	PERSHING

d. Army Aviation Activities:

(1) During the period 1 Feb 67 thru 30 April 1967, this headquarters gained operational control of the 176th and 185th Assault Helicopter Companies and the 225th Surveillance Aircraft Company.

(2) Personnel and equipment of the 176th Assault Helicopter Company closed this headquarters on 1 April and the unit became operational the same day. Equipment of the 196th Assault Helicopter Company closed this headquarters on 1 April and the unit became operational the same day.

(3) Aviation units under OPCON I FFORCEV participated in the following significant US operations in II CTZ during this reporting period.

(a) Major maneuver units supported in CTZ with aviation assets during the reporting period:

CONFIDENTIAL

32

AVFA-GC-OT

SUBJECT: Operational Report for Quarterly Period Ending 30 April
1967, RCS CSFOR-65 (U)

<u>UNIT SUPPORTED</u>	<u>NAME OF OPERATION</u>	<u>AVIATION SUPPORTING UNIT</u>	<u>PERIOD</u>
4th Inf Div	SAM HOUSTON	119th Aslt Hel Co 155th Aslt Hel Co 170th Aslt Hel Co 179th Aslt Sup Hel Co	1 Feb 67 thru 5 April 1967
4th Inf Div	FRANCIS MARION	119th Aslt Hel Co 155th Aslt Hel Co 170th Aslt Hel Co 179th Aslt Sup Hel Co	6 April 1967 thru 30 April 1967
1st Cav Div (AM)	THAYER II	119th Aslt Hel Co Organic Avn (1st Cav Div)	1 Feb 67 thru 11 Feb 67
1st Cav Div (AM)	PERSHING	119th Aslt Hel Co Organic Avn 1st Cav Div 179th Aslt Sup Hel Co (-)	12 Feb 67 thru 30 April 1967
1st Cav Div (AM)	DAZZLEM	Organic Avn 1st Cav Div	1 Feb 67 thru 2 April 1967
4th Inf Div	ADAMS	48th Aslt Hel Co 155th Aslt Hel Co 180th Aslt Sup Hel Co	1 Feb 67 thru 2 April 1967
1st Bde, 101st Abn Div	FARRAGUT	48th Aslt Hel Co 117th Aslt Hel Co 129th Aslt Hel Co 180th Aslt Hel Co	1 Feb 67 thru 17 Feb 67
1st Bde, 101st Abn Div	SUMMERALL	117th Aslt Hel Co 129th Aslt Hel Co 180th Aslt Sup Hel Co	30 March 1967 thru 29 April 1967
1st Cav Div (AM)	BYRD	Organic Avn 1st Cav Div	1 Feb 67 thru 29 April 1967

(b) ROK Operations

<u>UNIT SUPPORTED</u>	<u>NAME OF OPERATION</u>	<u>AVIATION SUPPORTING UNIT</u>	<u>PERIOD</u>
Cap ROK Inf Div	MAENG HO 8	161st Aslt Hel Co	3 Jan 67 thru 4 March 1967
Cap ROK Inf Div	OH JAC KYO I	161st Aslt Hel Co	15 March 1967 thru 22 March 1967
Cap ROK Inf Div	OH JAC KYO II	176th Aslt Hel Co	19 March 1967 continuing
Cap ROK Inf Div	OH JAC KYO II	161st Aslt Hel Co 176th Aslt Hel Co	18 March 1967 thru 26 March 1967

28

CONFIDENTIAL

33

CONFIDENTIAL

AVFA-GC-OT

SUBJECT: Operational Report for Quarterly Period Ending 30 April
1967, RCS CSFOR-65 (U)

<u>UNIT SUPPORTED</u>	<u>NAME OF OPERATION</u>	<u>AVN SUPPORTING UNIT</u>	<u>PERIOD</u>
9th ROK Div	BAEK M 1-1	174th Aslt Hel Co	28 Jan 67 thru 7 Feb 67
9th ROK Div	BAEK M 1-JL	174th Aslt Hel Co	14-22 Feb 67
9th ROK Div	OH JAC KYO I	174th Aslt Hel Co	8-15 March 1967
9th ROK Div	OH JAC KYO II	174th Aslt Hel Co	17 March 1967 thru 24 March 1967
9th ROK Div	OH JAC KYO II	174th Aslt Hel Co 155th Aslt Hel Co	19 March 1967 Continuing
9th ROK Div	BAEK MA II	155th Aslt Hel Co	31 March 1967 thru 15 April 1967

(c) ROK Forces were predominately supported by one Assault Helicopter Company per division, augmented with three CH47 aircraft per division. When conduct of operations reached a tempo requiring additional support, this headquarters increased the ROK aviation support on a mission basis by drawdown of aircraft allocated to support other combat units.

(4) Concurrently with the above US and ROK operations, the ARVN operations listed below were supported. This reporting period saw an increase in ARVN operations supported over the last quarter. No ARVN request for support was denied. The gain of one additional operational Assault Helicopter Company in II CTZ contributed to fulfill ARVN request for support. During this reporting period, one UH1D helicopter was allocated daily to each ARVN Ranger Battalion engaged in active field operations. This aircraft was under control of the advisor to the ARVN Ranger Battalion. ARVN aviation support was furnished on a mission basis by drawdown of aircraft allocated to other combat units. No support was allocated to ARVN Force on a continuing basis, except two UH1D and two UH1 armed helicopters to support ARVN counter activities against the VC tax extortion effort in vicinity of Bao Loc.

<u>PERIOD</u>	<u>NAME OF OPERATION</u>	<u>UNIT SUPPORTED</u>
6 Feb 67	6-67	24th Special Tac Zone
22 Feb 67	DAR LOC 21	23rd ARVN Div
24 Feb 67	DI LINH	23rd ARVN Div
2 March 1967	CAT BIRD I	23rd ARVN Div
3 March 1967	BA BINH VOUNG 802	22rd ARVN Div
4 March 1967	DAN THANG 135	24th Special Tac Zone
10 March 1967	MY THO 628	22d ARVN Div
10 March 1967	DAIM THANH 411	22d ARVN Div
10 March 1967	TRI DAO	24th Special Tac Zone
14 March 1967	DAN THANG 135	24th Special Tac Zone
17 March 1967	142	24th Special Tac Zone

29

CONFIDENTIAL

CONFIDENTIAL

34

AVFA-GC-OT

SUBJECT: Operational Report for Quarterly Period Ending 30 April
1967, RCS CSFOR-65 (U)

24 March 1967	THIEN MA 15	24th Special Tac Zone
30 March 1967	MOC TINH 309	22d ARVN Div
6 April 1967	BAC TIEN 818	22d ARVN Div
11 April 1967	AN DON 805	22d ARVN Div
13 April 1967 to 21 April 1967	LAM DONG	23d ARVN Div
14 April 1967	CHEO REO REACTION	22d ARVN Div
24 April 1967	LAM DONG I	23rd ARVN Div
28 April 1967	MOC TINH 317	22d ARVN Div

(5) I FFORCEV supported I CTZ, III CTZ and III MAF during this period as follows:

(a) CH54 "Crane" support was provided on request of MACV to both I and III CTZ and III MAF. CH54 helicopters were furnished by 1st Cav Div (AM).

(b) On 8 April 1967, the 282d Aslt Hel Co passed to OPCON III MAF with stationing at Da Nang. Two airlift platoons of this aviation unit were in direct support of DSA II CTZ until being deployed to I CTZ.

(c) Hq & Hq Co, 14th Combat Aviation Battalion and the 161st and 174th Aslt Hel Co passed to OPCON Task Force OREGON on 22 April 1967 for an indefinite period.

(6) There was no reported aircrew shortage in II CTZ this quarter.

e. Organization and Training Activities:

(1) Inclosure 8, I FFORCEV Task Organization shows all assigned and attached units, and those under operational control of I FFORCEV as of 30 April 1967.

(2) The command relationship of major US and FWMAF within II CTZ is shown in inclosure 9.

(3) Arrival, departure and reorganization of units.

(a) The following units were assigned to I FFORCEV during the period:

1. 41st Arty Gp, USARV GO (TBA).
2. 1st Bn, 92d Arty (155mm) (T), USARV GO 1195, 18 March 1967.
3. 4th Bn (AD), 60th Arty (AWSP), USARV GO 1195, 18 March 1967.
4. 6th Bn (8") (SP) 32d Arty, USARV GO 1417, 29 March 1967.
5. Btry E (MG), 41st Arty (AD), USARV GO 1195, 18 March 1967.

CONFIDENTIAL

CONFIDENTIAL

25

AVFA-GC-OT

SUBJECT: Operational Report for Quarterly Period Ending 30 April
1967, RCS CSFOR-65 (U)

29 March 1967. 6. Btry G (SLT), 29th Arty, USARV GO 1417,

GO 986, 5 March 1967. 7. Btry C, 6th Bn, 16th Arty (155mm) (T), USARV

(b) USARV GO 1886, 24 April 1967 attached the following
units to US Army TF CREGON (Prov).

1. 3d Bde, 25th Inf Div (GO to be published).

2. 3d Bn, (8") (SP), 18th Arty (-).

3. Trp C, 1st Cav Div Sqdn, 9th Cav.

(c) The following units were attached to 41st Arty Gp:

1. 1st Bn, 30th Arty (155mm) (T).

2. 4th Bn, 60th Arty (AD) (AWSF).

3. 5th Bn, 27th Arty (105mm) (T).

4. 6th Bn, 32d Arty (8") (SP).

5. 7th Bn, 13th Arty (105mm) (T)

6. Btry B, 29th Arty (Searchlight).

7. HHB, 8th Bn, 26th Arty (Tgt Acquisition).

(4) Training:

(a) Permission was obtained for 32 US observers to join
ROK forces during the period 16-30 March 1967 for the purpose of observing
tactics and techniques employed. At inclosure 10 is a copy of the LOI to
the observers and at inclosure 11 is a copy of lessons learned.

(b) NAADS: In February, Department of the Army directed
that the New Army Authorization Documents System be accelerated whereby
each assigned and attached units personnel and equipment allowances would
be reflected in one document - the MTOE. A cut off date of 31 Dec 66,
was established, then 16 MTOEs were prepared by a representative of the
Organization and Training Division at USARV. The program was also closely
monitored until the completion date, 25 March 1967, when MTOEs were forward-
ed thru USARPAC to Department of the Army for approval. I FFORCEV NAADS
MTOE reflected the following strength figures: 114 Officers, 2 Warrant
Officers, and 149 EM, total 265 personnel.

(c) MTOE: Because of the DOD Program 4 initiation, the
I FFORCEV MTOE which was submitted thru USARV to USARPAC in October 1966
was cancelled in January 1967 and returned for review and resubmission.
The Organization and Training Division conducted a review and analysis
of the document completing it at the end of the quarter for resubmission
to USARV. A personnel breakout reveals a request for a total of: 155
Officers, 2 Warrant Officers, and 224 EM.

(d) Gravel Mine: Because of numerous malfunctions in
the gravel mine subsystem, USARV suspended all usage of the mine on 20
March 1967 pending a complete investigation of the entire system.

CONFIDENTIAL

AVFA-GC-OT

SUBJECT: Operational Report for Quarterly Period Ending 30 April 1967, RCS CSFOR-65 (U)

(e) The 525th Military Intelligence Group provided training for all major OPCON organizations and ROKFV units on the use of the trace metal detection kit during the period 9-19 March 1967. Ten persons per class was the maximum number of student permitted. Up to three classes per brigade size organization were conducted.

(f) Thirty personnel received nuclear weapon refresher training in Korea during the period 21 Feb 67 - 4 March 1967.

(5) Doctrine and Analysis:

(a) Sniper evaluation: Representatives from USARV G3, Army Concept Team in Vietnam, and OPCON units visited I FFORCEV on 28 Feb 67 to discuss sniper operations, and requirements. The Organization and Training Division sponsored the meeting in which concepts, doctrine and equipment were discussed, and requirements for equipment were established by this division, in conjunction with OPCON units. This meeting was one of the most successful to date concerning sniper operations.

(b) Command relationships between US Army, USSF, and LLDB/CIDG commanders in II CTZ were clarified by CG, I FFORCEV. Co B, 5th SFGA and Det C-2, LLDB were assigned the additional mission of providing mutual support to US forces assigned to I FFORCEV. US forces are also assigned the mission of mutual support to USASF/LLDB/CIDG forces. In addition, US Special Forces personnel in CIDG camps that are within an area of operations assigned to a US commander are under the OPCON of that US commander, and are required to comply with his requirements. Conversely, commanders of US major combat units assigned an AO by I FFORCEV are tasked with the mission of providing reaction forces for CIDG forces within their AO's.

(c) Command interest in the Senior Advisor Monthly Evaluation (SAME) report of the effectiveness and state of training of ARVN forces precipitated a review and an extensive staff study of the SAME reports. The purpose of the staff study was to determine better ways of outlining the problems involved and prospective solutions. This headquarters continues to urge advisory personnel to aggressively promote and encourage training programs for ARVN at all levels of command. Mobile training teams in performing their normal function are setting the example on how effective training should be conducted.

f. Revolutionary Development:

(1) General

(a) During the reporting period activities within the I FFORCEV Revolutionary Development Support Division (RDSD) were characterized by increased provincial coverage and expanding responsibilities. In February 1967, two additional field representatives were appointed and areas of responsibility realigned to give full field representative coverage to II Corps Tactical Zone. The field representative concept has proven worthwhile and aided the Revolutionary Development Program by insuring overall coordination and use of available assets to support revolutionary development.

(b) In March 1967 the I FFORCEV Revolutionary Development Program Support Division was reorganized to provide for a Plans Branch, Operations Branch, Civil Affairs Branch, and Administrative Section. The reports and special duties section was incorporated into the Plans Branch, and the field representative were placed under the control of the Operations Branch.

3.7

CONFIDENTIAL

AVFA-GC-OT

SUBJECT: Operational Report for Quarterly Period Ending 30 April 1967, RCS CSFOR-65 (U)

(c) The RDSD Plans Branch participated in several planning conferences during the reporting period. The importance of the RD planning is recognized and is an integral part of the I FFORCEV planning cycle. Region II, Office of Civil Operations (OCO), participates actively in all revolutionary development planning activities to insure civilian/military coordination. Where available, Provincial RD plans were reviewed and spot checked in the field by field representatives.

(d) A revised study of RF/PF requirements for 1967 was presented to MACV for consideration and resulted in approval of 22 additional RF companies. These 22 companies will be recruited and trained this year and utilized primarily to provide increased security in revolutionary development areas.

(e) Five Region II Country Team meetings were held during the quarter. These meetings continue to foster understanding and cooperation between military and civilian elements. Region II Country Team meetings resulted in:

1. A study being conducted on a hamlet self defense system, in II Corps.
2. Increased effort to complete the construction of PW camps.
3. Joint planning for project EDAP ENANG, in Pleiku Province.
4. Close coordination on the employment of and security for the military/civil teams deployed in the Phu My area of Binh Dinh Province.

(f) The status of mobile training teams (MTT) instruction was closely monitored by RDSD. Sixteen ARVN Battalions completed the training during the period. In addition, 52 regional force companies completed the RD/MTT for RF. This training was considered to be successful and will be beneficial to the RD Program in the future.

(g) The new hamlet evaluation system (HES), instituted the first of the year, has led to a re-evaluation of the degree of control exercised by the GVN over the population. While this new system contains a more precise and definitive means of measuring control and progress, problems in initial evaluations, misunderstandings, and computer errors have reduced the effectiveness of the report. It is anticipated that the accuracy and value of this report will improve in the months to come.

(h) A new Joint Overview Report was developed in February 1967. This is a monthly report oriented on revolutionary development and contains the joint views and evaluations of the II Corps Senior Advisor and Director, Region II, Office of Civil Operations.

(2) Work on the 1967 Revolutionary Development Program for II Corps began in late February 1967. The 1967 program started late due to the TET holidays and finalization of some RD plans. As of 30 April 1967, Kontum, Binh Dinh, Pleiku, Phu Bon, Darlac and Khanh Hoa Provinces report they are on schedule while Binh Thuan, Lam Dong and Quang Duc Provinces are slightly behind schedule. Due to inaccuracies in the new hamlet evaluation system, no attempt has been made during this reporting period to determine the gain in secured hamlets and population. It is hoped that by next quarter more realistic data will be available in this area.

CONFIDENTIAL

CONFIDENTIAL

38

AVFA-GC-OT

SUBJECT: Operational Report for Quarterly Period Ending 30 April
1967, RCS CSFOR-65 (U)

(3) There were a total of 951 ROAD RUNNER Operations conducted during the quarter with the following results:

- (a) 36,952 kilometers traveled.
- (b) 13 enemy KIA.
- (c) 9 VC captured.
- (d) 34 suspects detained.
- (e) 9 weapons captured.
- (f) 74 obstacles removed.
- (g) 5 obstacles repaired.

(4) One hundred twenty four (124) COUNTY FAIR type operations were conducted in the II Corps Tactical Zone (CTZ) with these results:

- (a) 116 enemy KIA.
- (b) 165 VC captured.
- (c) 27 weapons captured.
- (d) 954 suspects detained.

(5) During the reporting period, the Viet Cong conducted a number of attacks against RD cadre teams. It has become evident that the VC are concerned over the success of the RD program and will concentrate their efforts against RD cadre and the hamlets they occupy. JGS Memo 056 (Translation of captured enemy documents) states the VC intention to disrupt the RD program. Also the Viet Cong Dong Suan (winter-spring) campaign lists as two of its objectives the destruction of new life hamlets in RD areas and execution of RD cadre through terrorist activities. To counter this threat, measures have been taken through MACV/OCO to improve coordination and security. RD cadre teams and RF/PF units are working more closely together to insure integration of available resources. The II Corps Commander has also initiated measures to counter this threat.

(6) Significant Field Representative Activities:

(a) Binh Thuan Field Representative:

1. Operation FARRAGUT was conducted by the 1st Bde, 101st Abn Div in an AC which included portions of Binh Thuan Province. The operation was effective in dispelling the myth of the impregnability of the VC secret bases in the area. The simultaneous operations of the 1st Bde, 101st Abn Div and Task Force 2d Bn, 7th Cav caused the VC to reinforce with a battalion in the northeastern part of the province. About two weeks after cessation of this operation, coupled with the closing of the National Training Center at Song Mao, one company of the Task Force 2d Bn, 7th Cav with one company of the 3d Bn, 44th ARVN Regt were directed to conduct combined search and destroy operations for security of the training facility. Upon departure of the 1st Bde, 101st Abn Div, the VC forces moved back into the area. The significance is that sufficient time was given to the enemy to react and move back into the area. The combined operation by Task Force 2d Bn, 7th Cav and ARVN netted about 75 VC KIA. This combined action also added

34

CONFIDENTIAL

CONFIDENTIAL

AVFA-GC-OT

SUBJECT: Operational Report for Quarterly Period Ending 30 April
1967, RCS GSFOR-65 (U)

a reasonable degree of security to the area which provided a better environment for the elections. The force was withdrawn to the Hop Luc priority area (Phan Thiet) for security of the village elections in the area. The provincial training center has been relocated to Song Mao, not only to take advantage of the better facilities, but as a means to increase the security in the area. The Task Force 2d Bn, 7th Cav plans to return to this area for further search and destroy operations.

2. Because of the extended operations of the Task Force 2d Bn, 7th Cav 202,000 of the 262,000 province population are considered secure. The priority area for Project Hop Luc is classed as secured; however, the enemy retains the capability to harass the RD teams and hamlets on the periphery of the area.

3. Efforts were instituted to expand the priority area to the northeast by constructing a strong point adjacent to Highway 1 (AN 904187) with a manning force of one ARVN company. The people accepted this fortification as an indication of permanence of security. As a result, 88 Hoi Chanhs were received from the two adjacent villages. This action, combined with an aggressive "TET" Chieu Hoi Campaign resulted in 430 Hoi Chanhs for February and March of 1967. During these two months, the 1966 total of Hoi Chanhs was exceeded by 106. Plans are being formulated to construct a similar strong point about ten kilometers further north on Highway 1.

4. Approval has been received for deployment of Civil Affairs teams on an area basis to support Revolutionary Development in the province. Two teams are being deployed now with a third team planned as assets become available.

5. The Headquarters, 44th ARVN Regt, returned to the province on 1 April 1967. This command element has been designed as the RD Campaign Headquarters. The primary function of the headquarters is to coordinate and direct ARVN military forces in proper security of RD teams and hamlets. Also this headquarters will supervise the functions of the RD teams. It had been reported in the March SJR and by the OCO representatives that the RD program for Binh Thuan had fallen behind schedule because of the lack of direction and supervision of the teams.

(b) Lam Dong, Quang Duc, and Tuyen Duc Field Representative:

1. Lam Dong: During the reporting period the RD progress in Lam Dong Province was rated from "progressing well" to "falling behind schedule". During the month of February 1967, a VC force in excess of two battalions occupied well prepared defense positions six miles west of the city of Di Linh, District Headquarters, interdicting National Highway 20; this action took place within three kilometers of two RD hamlets, one of which was cleared of its residents and occupied by part of the VC force. A two day battle ensued with the commitment of five RF companies, one ARVN Ranger Bn reinforced and one battalion of the 1st Bde, 101st Abn Div.

a. The results of this short but hard fought engagement had a definite, detrimental effect on the RD Program. Subsequent reports during March indicate the confidence of the people in the hamlets adjacent to the battle area has declined.

b. As March grew to a close, indications were that the VC had returned to their harassing tactics of kidnapping, murdering, propagandizing, and attempting small attacks on secured hamlets. Nightly, RD hamlets received harassing fire; the secured hamlet

CONFIDENTIAL

CONFIDENTIAL

40

AVFA-GC-OT

SUBJECT: Operational Report for Quarterly Period Ending 30 April
1967, RCS CSFOR-65 (U)

of Tan Rui Thuang was attacked and the medical dispensary and town hall destroyed by demolitions. The residents have since abandoned the village and are in the process of dismantling and moving the village into the city of Bao Loc.

c. The loss of an extremely capable district chief, who was killed during the battle of 24 February 1967, will have a damaging effect on the RD program in the Di Linh District.

2. Tuyen Duc: During the reporting period the 1967 RD program continues to be slightly behind schedule. RD teams are establishing themselves in their hamlets and some improvements are noted in their operations. However, the failures on the part of RD teams and other agencies to eliminate VC infrastructure in five of the eleven hamlets currently undergoing pacification is preventing the teams from effectively carrying out their other hamlet development activities.

a. Joint US/ARVN weekly inspections of the RD areas are being conducted. There has been an increase in VC harassing activities against RD teams and the lack of any US or ARVN maneuver force has limited the province's ability to deter VC incidents against RD teams.

b. In summary, RD teams have a long way to go but significant improvements have been made over the 1966 program.

3. Quang Duc Province:

a. During the last three months, the Revolutionary Development Plan for 1967 has fallen behind schedule. To compensate for this, the province has slipped all Phase II plans back two months. This action will result in a cramped working schedule for Phase V in order to complete the plan prior to 1 January 1968.

b. The province is handicapped in its support of the RD program due to the lack of transportation. The RD Chief is highly motivated and ambitious and with the necessary provincial support he could do much to put the program back on schedule.

(c) Binh Dinh and Phu Yen Field Representative:

1. Binh Dinh:

a. The 1967 RD program was initiated in the National Priority Area, comprised of Tuy Phuoc, An Nhon, Binh Khe and Phu Cat Districts. A total of 30 RD teams are currently in the province, and the program is progressing on schedule. In compliance with the Inter-Ministerial Directive, Subject: Organization of Revolutionary Development Campaigns in the Province, eight RD Campaign Headquarters have been established.

b. In Phu My the Military/Civil Teams were deployed in twelve hamlets to conduct initial pacification measures. As evidence of progress, ten schools have been reopened in these hamlets, with a pupil population of 605. Over 2700 refugees have returned to the hamlets involved. Interest has been generated in adjacent hamlets to improve their conditions even before the arrival of Military/Civil Teams.

2. Operation PERSHING by the 1st Cav Div (AM) and the 22d Inf Div (ARVN) is opening new areas in northern Binh Dinh to GVN control. One of the most important is the coastal plain along National Highway 1 from Bong Son to Tam Quan in Hoai Nhon District.

CONFIDENTIAL

41
CONFIDENTIAL

AVFA-GC-OT

SUBJECT: Operational Report for Quarterly Period Ending 30 April
1967 RCS CSFOR-65 (U)

2. Phu Yen: With the termination of Operation OH JAC KYO, the Cap ROK Inf Div and the 9th ROK Inf Div TAOR's have been joined in Phu Yen Province. In addition to the ROK forces, three battalions of the 47th ARVN Regiment are deployed in the province. One of these battalions is in direct support of RD. The battalion commander has been appointed RD Campaign Commander in Tuy Hoa Subsector. He has integrated the employment of the ARVN/RF/PF forces with RD teams to improve security for the RD program.

(d) Pleiku, Darlac and Kontum Field Representative: The most significant activity in these three provinces, where the 1967 RD Program is now schedule, was the initiation of Project EDAP ENANG (Border of Love) in which some 10,000 Montagnards are being relocated from the Pleiku border combat area, to a resettlement camp further to the east. On 30 April 1967, approximately 1/3 of the population involved had been moved and houses were being constructed, some by the GVN and others by the Montagnards themselves. It is estimated that the resettlement area will be self-sustaining foodwise in about seven months, meanwhile the Province and OCO are providing foodstuffs.

(7) Civil Affairs Operations:

(a) The G3 RD section continued to monitor civil affairs activities and specifically the Civic Action Programs of the OPCON units, DSA II Corps/II Corps Advisory Group, and II CTZ Installation Coordinator System.

(b) There has been added emphasis during the quarter by US units and MACV Advisors to influence RVNAP to accomplish Civic Action programs for the Vietnamese People. One of the major factors in this direction is the two week Mobile Training Team Course given to all ARVN battalions and RF/PF units.

(c) Up-dating of all province area surveys continued throughout the quarter. The surveys for Darlac and Ninh Thuan Provinces were completed and published by the 41st Civil Affairs Company. Priorities were established for updating of Binh Dinh and the early completion of Khanh Hoa, Pleiku, and Kontum surveys.

(d) Evacuation of rice from inaccessible areas continued to be a problem. Rice bags have been available in sufficient quantities through the Province OCO Representative for the evacuation of the rice that was accessible.

(e) The Area Real Estate Office continued to coordinate the efforts of all US elements using Vietnamese facilities. During the quarter 81 new leases were executed and 99 old leases were renegotiated resulting in a total saving of 5,181,470 VN\$ (\$43,800).

(f) The use of the 41st Civil Affairs Company in the Area Support role was approved by CG, I PFORCEV, in April 1967. Each division and separate brigade will retain one Civil Affairs Team each and the remaining teams will be relocated within the II CTZ where they can best support Revolutionary Development.

(g) The Community Relations Program received increased command emphasis from MACV and USARV. Ways and means are being sought to further lessen the US impact on the Vietnamese economy. Programs already initiated during the past quarter include: Renegotiation of leases to within American Embassy limits, curfew restrictions, establishment off-limits to certain parts of towns, reduction of piasters expenditure, movement of troops from villas to less expensive hotels or to out-of-town billeting areas, and limitations on passes.

37
CONFIDENTIAL

CONFIDENTIAL

42

AVFA-GC-OT

SUBJECT: Operational Report for Quarterly Period Ending 30 April
1967, RCS CSF)R-65 (U)

g. Psychological Operations:

(1) General:

(a) During the reporting period psychological operations were conducted by FWMAF and GVN in the II Corps Tactical Zone (CTZ) supported by the 245th PsyOp Company (-) Nha Trang and Pleiku (15 officers and 41 enlisted men), the 9th Air Commando Squadron (ACS), the 6th PsyOp Bn, Saigon, the 7th PsyOp Gp, Okinawa, the US Coastal "Junk and Swift" Fleet, the 20th PLWAR Bn (ARVN) and the 114th Liaison Squadron (VNAF).

(b) In II CTZ operations, 370,112,300 leaflets were disseminated of which 42,086,000 were printed by the 245th PsyOp Co. A total of 328,026,320 leaflets were disseminated in II CTZ from the 6th PsyOp Bn and 7th PsyOp Gp. In addition 1,048:10 hours of aerial loudspeaker time was directed to targets in enemy areas.

(c) Leaflets and loudspeaker operations were in support of tactical and revolutionary development operations; BYRD, PICKETT, FARRAGUT, THAYER II, DAZZLEM, SAM HOUTSON, ADAMS, FRANCIS MARION, SUMMERALL, PERSHING, MAENG-HO 8, BACK MAI, MA-DOO 1 and B1 MA 3 in II CTZ.

(d) The objective of leaflets used before tactical and revolutionary development support operations were generally:

1. Population control.
2. Cause population to deny support to VC/NVA elements.
3. Describe to VC/NVA and local populace the terms of the Chieu Hoi program.
4. Cause populace of VC/NVA controlled areas to expose VC/NVA personnel.
5. Cause populace in contested areas to accept and support the cause of the GVN.

(e) The objectives of leaflets and loudspeaker operations during tactical operations were:

1. Demoralize VC and NVA troops.
2. Cause defections in VC/NVA ranks.
3. Assure potential POWs and Hoi Chanh of fair treatment.
4. Exploit Hoi Chanh to effect desertion of VC/NVA personnel.
5. Alienate the VC/NVA forces from the populace.
6. Create a fear of impending doom in VC/NVA personnel should they continue to fight.

(f) Leaflets used prior to an operation gave safety instructions to the populace and rally instructions to VC/NVA sympathizers and troops.

CONFIDENTIAL

CONFIDENTIAL

43

AVFA-GC-OT

SUBJECT: Operational Report for Quarterly Period Ending 30 April
1967, RCS CSFOR-65 (U)

(g) For examples of leaflets used in tactical operations in II CTZ, see:

1. Incl 12, quick reaction and special leaflets.
2. Incl 13, demoralization leaflets.
3. Incl 14, pacification leaflets.

(h) Results of psychological operations shows 3,290 returnees (Hoi Chanhs) for the period 1 Feb to 21 April 1967, an increase of 606 over last quarter. The returnee total since 1 Jan 66 is 13,198 in II CTZ.

(i) Aerial loudspeaker missions were flown in conjunction with, and support of, separate operations down to, and including platoon size units. A total of 857 aerial loudspeaker sorties were flown by US Air Force aircraft and 116 loudspeaker sorties were flown by army aircraft in II CTZ.

(j) Eight two man loudspeaker teams (HB) from the 245th PsyOp Company were attached to US OPCON units and ROKs for major operations in II CTZ. The direct support role of the loudspeaker teams was effective in population control and in support of the Chieu Hoi Program when employed in a new village and/or hamlet, used in search and clear operations.

(2) Support:

(a) Leaflets disseminated in II CTZ during the reporting period were provided by:

- | | |
|--------------------------------------|-------------|
| 1. 6th PsyOp Bn, Saigon | 97,420,000 |
| 2. 7th PsyOp Gp, Okinawa: | 224,606,300 |
| 2. 245th PsyOp Co, Nha Trang/Pleiku: | 48,068,000 |

(b) The 9th ACS flew a total of 1,621 PsyOp missions, disseminating 358,402,720 leaflets and provided 1,032 hours of loudspeaker broadcasts. There were no flights cancelled due to aircraft non-availability, however, there were 275 missions cancelled of the 1,896 requested because of weather or maintenance.

(c) Boats of the "Junk and Swift" Fleet, fitted with loudspeakers completed seventeen hours of loudspeaker broadcasts and disseminated 250,000 leaflets to selected target audiences in operations along the II CTZ coastal areas.

(3) Operations and Training: PsyOp annexes of contingency plans for five proposed operations in II CTZ have been prepared with maximum emphasis being placed on use of accurate, timely intelligence to develop meaningful propaganda materials rather than the use of standard, nation wide materials.

(4) Enemy Propaganda: Analysis of the enemy propaganda shows an increasing indication that Viet Cong propaganda is directed mainly toward countering American propaganda rather than creating new themes for their own use.

CONFIDENTIAL

SECRET

44

AVFA-GC-OT

SUBJECT: Operational Report for Quarterly Period Ending 30 April
1967, RCS CSFOR-65 (U)

h. Chemical.

(1) General.

(a) On 1 Feb 67 LTC Skinner E. Anderson assumed the duty of Chemical Officer, I FFORCEV.

(b) To expedite herbicide project processing, the Deputy Senior Advisor, II CTZ submitted a proposed change to MACV Directive 525-1, dated 15 Feb 66, on 25 Feb 67. The proposed change permitted US/FWMAF units to submit requests for herbicide projects to the Province Chief concerned through the appropriate Sector Advisory Team rather than through CG, I FFORCEV to CG, II CTZ for subsequent forwarding to the Province Chief. This proposed change was approved by MACV on 18 March 1967 and was disseminated to OPCON units by message on 22 March 1967.

(c) Even though the procedural change in subparagraph (1) (b) above shortened the herbicide project processing time by approximately one month, the three to five month processing time still required is unresponsive to the needs of the tactical commanders and province chiefs. On 12 Feb 67 this headquarters sent a letter to LTG Vinh-Loc, CG, II CTZ requesting that he initiate large area herbicide projects within II CTZ to include suspected secret base areas, infiltration routes and recurring enemy operational areas. Under the concept of this "Omnibus Plan", specific targets within the large approved project areas can be attacked as needed or as the opportunity is presented. This provides the province chief and the tactical commanders with maximum flexibility for herbicide operations. The response time to attack a herbicide target will be reduced from months to days. In addition, the province chief has the authority to suspend operations in all or a portion of any project as the need arises. LTG Vinh-Loc approved the concept and forwarded the plan to the province chiefs on 8 April 1967 for preparation of the necessary project requests. The Deputy Senior Advisor, II CTZ submitted a parallel request to the Sector Advisory Teams on 2 April 1967.

(d) On 13 April 1967 the I FFORCEV Chemical Section assumed the responsibility for receiving the "Trail Dust" (herbicide mission) warning order from TACC and obtaining target clearance from the appropriate agency. The assignment of this mission to the Chemical Section permits a more rapid corrective action if target coordinates do not correspond to active projects or if a mission should be changed to another project to higher priority.

(e) On 13 April 1967 weather in the PERSHING AO would not permit Air Force Jet cover for a "Trail Dust" mission. Helicopter gunships were used for air cover permitting completion of a mission that would otherwise have been cancelled. Consideration is being given to the use of gunships as standby cover in the event high performance aircraft cannot cover the "Trail Dust" mission.

(f) On 21 March 1967 the 1st Bde, 1st Cav Div (AM) ran one of many non-persistent CS missions in the PERSHING AO using M7A3 grenades with the Adapter Kit, Troop Landing Smoke Screen System for XM3 2.75 - inch Rocket Launcher. This mission was run on a suspected enemy position in the Bong Son Plain vicinity AN Qui (2). On 25 March Sergeant Teo (Squad Leader, 7th Bn, 22d Regt, 3d NVA Div) surrendered to the 1st Brigade. He stated that he was in a foxhole on 21 March 1967 An Qui (2) when hit by gas. He experienced vomiting, headache, running eyes and nose, and was temporarily blinded. He

40

SECRET

SECRET

45
AVFA-GC-OT

SUBJECT: Operational Report for Quarterly Period Ending 30 April 1967, RCS CSFOR-65 (U)

had an NVA plastic protective mask which afforded little protection. He withstood the CS concentration because of artillery fire. He further stated that he was incapacitated for approximately 15 minutes during which time he would have been unable to defend himself had he been attacked.

(g) Enemy use of Agent CS.

1. MACV message 11545 from MACJ262, 071319Z April 1967 states that on 6 April 1967 the mortar platoon, 3rd Bn, 8th Inf, 4th Inf Div was attacked by an enemy force employing a chemical agent which has been identified as CS powder. Identification was based on smell, color, size of particles, observed effect on personnel and limited laboratory analysis. Approximately one pound of the chemical agent in powder form was sealed in gray plastic and black rubber pouches. Four Vietnamese soft drink bottles containing traces of the CS powder was shaken out into the 5 - 8 knot wind which carried the CS into the US perimeter providing a mild CS attack effect.

2. On 18 April 1967, the Duc Co OP was attacked by an enemy force employing grenades to which bags of tear gas had been attached.

3. Both of the above incidents occurred in the FRANCIS MARION AO in which bulk CS-1 had been employed by the 4th Inf Div (see subparagraph 3 h (4) (b) below).

(h) NIC Report No 165/67, 17 Feb 67, Subject: Effects of Defoliation in Binh Dinh Province states that defoliation operations in certain districts of Binh Dinh Province resulted in total crop destruction, but in spite of this, the civilians and soldiers in the VC-controlled areas were still willing to continue military and production activities. Leaflets were dropped prior to the defoliation operation, but the people did not believe them, because they were told that there would be no defoliation. After defoliation the majority of civilians moved to Government of Vietnam (GVN) controlled areas, and the minority who remained behind had to replant their crops with little or no help from the VC. They obtained new seed from nearby villages, and the VC obtained food supplied from villages not hit by defoliation; therefore, though extensive, the defoliation operations did not critically impede VC activities. The date of the information in the report is from April 1965 to October 1966. During this period an active crop destruction project existed in Binh Dinh Province.

(i) NIC Report No. 231/67, 10 March 1967, Subject: Effects of Defoliation in Kontum Province, SVN, states that the source reported seeing the effects of "chemical powder" in Kontum Province, SVN. He reported seeing "dead" branches and completely dead trees over a very large area. The chemical powder destroyed both manioc and rice plants. The destruction caused food shortages, according to civilians with whom the source had conversed. He did not learn how long the shortage had lasted, however, nor their seriousness. These same civilians said that the powder was very potent and killed both plants and trees. VC Political Officers were using the effects of defoliation to drum up support for the VC, by telling the people the US and SVN government were trying to destroy their food supplies. Nevertheless, the people, who were poor, were still required to give rice to the VC troops. The date of the information in the report is from February to December 1966. During this period an active crop destruction project existed in Kontum Province.

11

SECRET

SECRET

46

AVFA-GC-OT

SUBJECT: Operational Report for Quarterly Period Ending 30 April
1967, RCS CSFOR-65 (U)

(2) Crop Destruction Operations: See Incl 15.

(a) The following twelve projects were active during this reporting period, five of these projects were previously approved by COMUSMACV.

1. Project 2-22 consisted originally of six target areas in Northern Phu Yen Province. Targets 4, 5 and 6 were reinitiated for the period February 1967 through December 1967. A total of 19 UC-123B spray aircraft sorties covering approximately 2,850 hectares of crop were flown in this project during the reporting period. Adverse weather severely hampered herbicide operations in this project.

2. Project 2-31 consisted of two target areas in Tuyen Duc Province containing approximately 800 hectares of rice. Since crops were harvested prior to execution, no sorties were flown in this project. The project expired on 28 Feb 67.

3. Project 2/2/1/66 consists of four target areas covering approximately 60 per cent of Kontum Province and containing approximately 6,000 hectares of rice, manioc, potatoes and corn. The project was reinitiated on 14 Feb 67 for the period 17 Feb 67 through 31 Dec 67. This project was approved for both crop destruction and defoliation (see subparagraph (3) (a) 2 below. No crop destruction sorties have been flown to date.

4. Project 2/2/2/66 originally consisted of three target areas containing approximately 2,500 hectares of various crops. A fourth target area containing approximately 300 hectares of crops was added to the project in March 1967. This project is approved for the period March 1967 through December 1967. No sorties were flown during this reporting period.

5. Project 2/2/3/66 consists of nine target areas in Phu Bon Province containing approximately 850 hectares of rice and corn. The project is approved for the period 24 April 1967 through 9 April 1968. No sorties were flown during this reporting period.

6. Project 2/2/5/66 consists of three target areas in Darlac Province containing approximately 300 hectares of row crops. The project is approved for the period February 1967 through December 1967. No sorties were flown during this reporting period.

7. Project 2/2/6/66 consists of five target areas in Ninh Thuan Province containing approximately 10,000 hectares of rice, corn and manioc. This project is approved for the period February 1967 through December 1967. Two UC-123B spray aircraft sorties covering approximately 300 hectares of crops were flown during this reporting period.

8. Project 2/2/7/66 consists of 15 target areas in Pleiku Province containing approximately 1500 hectares of various crops. This project is approved for the period 6 April 1967 through 5 April 1968. No sorties were flown during this reporting period.

9. Project 2/2/1/67 consists of seven target areas in Binh Dinh Province containing various crops. This project is approved for the period 5 Jan 67 through 31 Dec 67. A total of 53 UC-123B spray aircraft sorties covering approximately 7,950 hectares of crops were flown during this reporting period.

42

SECRET

SECRET

47
AVFA-GC-OT

SUBJECT: Operational Report for Quarterly Period Ending 30 April 1967, RCS CSFOR-65 (U)

10. Project 2/2/4/67 consists of one 9,100 hectares target area in Pleiku Province containing rice. This project is approved for the period 6 April 1967 through 5 April 1968. No sorties were flown during this reporting period.

11. Project 2/2/5/67 was originally requested for four small targets in southern Ninh Thuan Province. The project was expanded at the final coordination meeting to make one large target area encompassing the four small one. Rice, corn and manioc are grown in the target area. This project is approved for the period 28 April 1967 through 25 April 1968. No sorties were flown during this reporting period.

12. Project 2/2/9/67 consists of six target areas in eastern Pleiku Province containing approximately 1,000 hectares of paddy rice. This project is approved for the period 6 April 1967 through 5 April 1968. No sorties were flown during this reporting period.

(b) The following five projects requested are currently being processed by MACV. Three of these projects were requested during the reporting period.

1. Project 2/2/1/67 consists of seven active target areas in Binh Dinh Province. Two additional targets in the An Lao and Suoi Ca Valleys have been requested by the 1st Cav Div (AM). Principal crops in the area include rice, corn and sugar cane. The supplemental Deputy Senior Advisor's position was forwarded to MACV on 22 April 1967 recommending project approval.

2. Project 2/2/3/67 consists of six target areas in Phu Yen Province containing approximately 6,000 hectares of rice. This project includes targets 4, 5 and 6 of approved project 2-22 (see subparagraph (2) (a) 1 above) in addition to three other targets in southern Phu Yen Province. The Deputy Senior Advisor's position was forwarded to MACV on 28 Feb 67 recommending project approval.

3. Project 2/2/8/67 consists of 11 target areas in Khanh Hoa Province containing approximately 850 hectares of rice, corn and manioc. The Deputy Senior Advisor's position was forwarded to MACV on 14 Jan 67 recommending project approval.

4. Project 2/2/10/67 consists of one target area of 1,100 hectares containing rice and corn. The Deputy Senior Advisor's position was forwarded to MACV on 29 March 1967 recommending project approval.

5. Project 2/2/11/67 consists of three target areas containing approximately 600 hectares of rice, corn and sweet potatoes. One target area corresponds to a target area in approved project 2/2/5/66 (see subparagraph (2) (a) 6 above). The Deputy Senior Advisor's position was forwarded to MACV on 17 April 1967 recommending project approval.

(3) Defoliation Operations: See Incl 15.

(a) The following eight projects were active during this reporting period. Four of these projects were previously approved by COMUSMACV.

SECRET

CONFIDENTIAL

48.

AVFA-GC-OT

SUBJECT: Operational Report for Quarterly Period Ending 30 April 1967, RCS CSFOR-65 (U)

1. Project 20-50 originally consisted of 10 target areas along Highway 1 and the National Railroad in Binh Thuan Province. Eight targets were initially approved for the period June 1966 through January 1967 with a subsequent extension through 30 June 1967. Spraying was started in June 1966 but was suspended in July 1966 by the Province Chief. The VC were capitalizing on the spraying with propaganda that spraying was poisoning the populace.

2. Project 2/2/1/66 is a dual crop destruction and defoliation project consisting of four target areas covering approximately 60 per cent of Kontum Province (see subparagraph (2) (a) 3 above). Defoliation of Highway 512 West of Dak To, the extension of Highway 509 and a series of 4th Inf Div projects in southwestern Kontum have been attacked during the reporting period with 71 UC-123B spray aircraft sorties covering approximately 10,320 hectares.

3. Project 2/20/3/66 originally consisted of three target areas near the Dong Ba Thin-Cam Ranh Bay Complex in Khanh Hoa Province. Two targets were initially approved for the period August 1966 through December 1966 with a subsequent extension through 30 June 1967. One target was cancelled. The project was approximately 75 per cent completed but has been placed on "hold" by the 10th Aviation Battalion as no longer required. The project has been requested for extension by this headquarters to supplement the "Omnibus Plan" (see subparagraph (1) (c) above).

4. Project 2/20/4/66 originally consisted of 11 target areas along Highway 7B and 2E and provincial roads in Phu Bon Province. Eight targets were initially approved for the period September 1966 through 31 December 1966 with a subsequent extension through 30 June 1967. Project execution has been suspended at the request of the Province Chief. No sorties were flown during this reporting period.

5. Project 2/20/5/66 consists of four target areas around the Dak Pek Special Forces Camp in northwestern Kontum Province. The project was approved for the period July 1966 through 1 March 1967. During this reporting period 10 UC-123B spray aircraft sorties covering approximately 1,130 hectares were flown.

6. Project 2/20/7/66 consists of three target areas in the mountainous regions in northern Khanh Hoa Province. The project was requested by this headquarters to support proposed operations into the Haroi area. The project is approved for the period April 1967 through 9 April 1968. During this reporting period 12 UC-123B spray aircraft sorties covering approximately 1800 hectares were flown.

7. Project 2/20/1/67 consists of 14 targets covering approximately 420 square kilometers of area along lines of communications, around installations and in proposed areas of operations in Binh Dinh Province. This project was approved on 16 April 1967 with the final coordination meeting scheduled for 2 May 1967. No sorties were flown during this reporting period. This project was renumbered from 2/30/3/67.

8. Project 2/20/20/4/67 was originally requested for 10 target areas along major roads, Viet Cong secret bases and the RVN Cambodian border in Pleiku Province. An additional target was requested along the extension of Highway 509B. All 11 target areas were approved for the period April 1967 through 5 April 1968. During this reporting period eight UC-123 spraying aircraft sorties covering approximately 1200 hectares were flown.

44

CONFIDENTIAL

49

CONFIDENTIAL

AVFA-GG-OT

SUBJECT: Operational Report for Quarterly Period Ending 30 April 1967, RCS CSFOR-65 (U)

(b) The following five projects are currently being processed at MACV. Two of these projects were requested during the reporting period.

1. Project 2/20/6/66 was originally requested for five targets along Highway 20 and provincial roads in Lam Dong Province. USAID representatives at sector and DSA, II CTZ did not concur in the project. A new request for one target was submitted by the Province Chief along Highway 20. The Deputy Senior Advisor's position for the new target, including USAID concurrence, was forwarded to MACV on 14 March 1967 recommending approval.

2. Project 2/20/2/67 was requested for four target areas along the National Railway in Binh Thuan Province. The Deputy Senior Advisor's position was forwarded to MACV on 17 Jan 67 recommending approval. The project was returned by MACV recommending disapproval due to the close proximity of the target areas to friendly crops. The project has been referred to DSA, II CTZ for a determination by the Binh Thuan Sector Advisor of the project validity. This project supplements project 20-50 (see subparagraph (3) (b) (1) above).

3. Project 2/20/3/67 was requested for 20 target areas along the major lines of communications in Phu Yen Province. One target area along Highway 1 is considered invalid due to the proximity of a large friendly population and sparse vegetation in the area. The Deputy Senior Advisor's position was forwarded to MACV on 29 March 1967 recommending approval of the 19 valid target areas.

4. Project 2/20/6/67 consists of six target areas along Highway 14 and 8 and provincial roads in Quang Duc Province. The Deputy Senior Advisor's position was forwarded to MACV on 17 Jan 67 recommending project approval.

5. Project 2/20/8/67 consists of three target areas along major line of communication. The Deputy Senior Advisor's position was forwarded to MACV on 17 April 1967 recommending project approval.

(c) The following ground based defoliation was completed during this reporting period:

1. On 9 March 1967 in 24th Special Tactical Zone, Kontum sector sprayed along lines of communication from ZA 209946, ZA 206953 with a Buffalo Turbine. Approximately 10 hectares of bamboo and pine were sprayed with approximately 80 per cent of the vegetation defoliated.

2. During the period 5-14 Jan 67, the 633d Combat Support Group (PACAF) sprayed approximately two hectares of grass and bushes around the outer perimeter fence of Pleiku AFB using hand sprayers and a compressed air sprayer. Defoliation cleared the perimeter with excellent results.

3. During the period 15-20 Jan 67 the 52d Aviation Battalion sprayed approximately 10 hectares of grass and bushes around the Camp Holloway perimeter and ammunition storage area with hand sprayers. This operation cleared the perimeter for better visibility and reduced vegetation in the ammunition storage area with excellent results.

45

CONFIDENTIAL

CONFIDENTIAL

50

AVFA-GC-OT

SUBJECT: Operational Report for Quarterly Period Ending 30 April 1967, RCS CSFOR-65 (U)

4. During the period 11-13 Jan 67, the 1st Cav Div (AM) sprayed approximately 100 hectares of the Y-ring at Camp Radcliff using a CH-47 spray rig. A combination of trees, shrubs and grass, densely vegetated, was only partially defoliated. The poor results are attributed to application of insufficient agent.

5. On 20 Feb 67 the 1st Cav Div (AM) defoliated two separate targets with a CH-47 spray rig, approximately 100 hectares of a cave complex located in the vicinity of BR 7465 were defoliated with satisfactory results. Approximately 30 hectares of an old land mine area within Camp Radcliff (vicinity BR 472444) were defoliated in preparation for burning and clearing. On 8 April 1967 this area was burned. Even though the area was completely brown, WP grenades would not start a fire in the area. Diesel fuel sprayed over a portion of the area was required to start a "good" fire.

6. On 28-29 March 1967 the 1st Cav Div (AM) sprayed on the northern portion of the Camp Radcliff D-Ring using a CH-47 spray rig. This mission was very effective. Plans are being made to burn the dead vegetation.

7. During the period 2 Jan 67 through 30 April 1967 the 4th Inf Div sprayed approximately 270 hectares of single, double and triple canopy jungle along Highway 509B from YA 945434 and from ZA 0242 to ZA 0443 using PDDA, UH-1D and CH-47 spray rigs. Leaf kill varied from 20-85 per cent with an increase in visibility from 0 to 75 per cent depending on the lapsed time from spraying.

8. During the period 12-21 March 1967, the 4th Inf Div sprayed approximately 32 hectares of double and triple canopy jungle around fire support bases at YA 610600, YA 757386 and YA 732504 using a UH-1D spray rig. As of 14 April 1967 the area showed 20-30 per cent leaf kill.

9. During the period 15 Feb 67 to 5 March 1967, the 4th Inf Div sprayed approximately 28 hectares of grass, brush and low trees around the Dragon Mountain Base Camp (AR 8035) and LZ 3T (YA 8545) with Mity Mites, a Buffalo Turbine and a UH-1D spray rig to increase visibility and clear fields of fire. Defoliation results were excellent.

10. On 7-8 April 1967 the 4th Inf Div sprayed approximately 15 hectares of Highway 19 and trails in the vicinity of YA 7723 using a UH-1D spray rig. Results are unknown as of this report.

11. On 14-15 April 1967, the 1st Bde, 101st Abn Div sprayed approximately 210 hectares of foliage around the Brigade Base Camp at Phan Rang using a CH-47 spray rig. Results are unknown as of this report.

(4) Riot Control Agent (RCA) Operations.

(a) Use of M7A3 grenades: In Operation THAYER II and PERHING, the 1st Cav Div (AM) employed CS grenades against enemy positions. During two missions enemy fire was received and air strikes were directed at the enemy positions resulting in VC structures destroyed. In Operation SAM HOUSTON the 4th Inf Div employed 443 CS grenades against a known enemy position in conjunction with artillery fire. The aircraft received enemy fire during the mission. However, no enemy casualties were found by a LRRP searching the area the following day.

46

CONFIDENTIAL

CONFIDENTIAL

51

AVFA-GC-OT

SUBJECT: Operational Report for Quarterly Period Ending 30 April
1967, RCS CSFOR-65 (U)

In Operation FARRAGUT the 1st Bde, 101st Abn Div employed 1136 CS grenades against suspected enemy locations. During one mission 4-5 VC were engaged with unknown results.

(b) Use of Bulk CN/CS-1: In Operation BYRD Task Force 2d Bn, 7th Cav used M5 Riot Control Agent Dispersers to employ bulk CS-1 on VC market places and dry stream beds used as infiltration/exfiltration routes. In an effort to cause area denial, the 1st Cav Div (AM) dropped in excess of 25,000 pounds of bulk CS-1 in 55 gal drums from a CH-47 during Operations THAYER II and PERSHING. The drums were equipped with fuzes and an M-10 Destructor to blow up the drums at or near ground level for agent dissemination. The 4th Inf Div employed more than 7,100 pounds of bulk CS-1 from CH-47's during the conduct of Operations SAM HOUSTON and FRANCIS MARION. These missions were used in bunker contamination and terrain denial. The 1st Bde, 101st Abn Div employed approximately 1,500 pounds of bulk CS-1 against suspected enemy locations during Operations FARRAGUT and SUMMERALL. In addition, the 1st Bde, 101st Abn Div used in excess of 2,000 pound of CN to deny a pass as a VC exfiltration route during Operation FARRAGUT. The agent was dropped from a UH-1 in either 8 pound or 20 pound bags (original shipping package) rigged with detonating cord and a fuze timed to explode at or near the ground.

(5) Flame Operation.

(a) Flame fougasse and illuminators are installed around the perimeters of unit base camps. These require frequent inspection and servicing to insure readiness. The most frequent problem areas encountered include fuel breakdown, faulty wiring or accidental wire breakage and inadvertent detonation during thunderstorms.

(b) On 11 March 1967 the 1st Cav Div (AM) dropped nine 55 gal drums of napalm into a rock formation and cave complex in the vicinity of BS 8206. Because of the close proximity of friendly troops to the complex, the drop was made from a CH-47 at 1200 feet and was guided by an aerial observer. During the drop friendly troops withdrew only 50-100 meters from the target. Eight of the nine drums detonated. One man came out of the complex while the napalm was still burning and was taken prisoner.

(6) Summary.

(a) Herbicide Operation.

1. General: Unit commanders feel that the herbicide program in II CTZ is unresponsive to the tactical needs. To partially alleviate this problem, MACV approved a change to the herbicide directive that permitted the US/FWMAF units to submit project requests directly to the province chief concerned through the appropriated sector advisor. In addition, this headquarters has requested that the CG, II CTZ initiate large area herbicide projects within II CTZ. Once these large areas are approved, specific targets can be attacked as the need or opportunity arises.

2. Crop Destruction Operations: There are currently 11 active crop destruction projects in II CTZ. Of these projects seven were approved by COMUSMACV since the last report. One project expired during this reporting period. A total of 79 UC-123B spray aircraft sorties were flown attacking approximately 11,000 hectares of crops. Five projects are currently being processed through MACV. Of these projects two were submitted since the last report

47

CONFIDENTIAL.

CONFIDENTIAL

52

AVFA-GC-OT

SUBJECT: Operational Report for Quarterly Period Ending 30 April
1967, RCS CSFOR-65 (U)

3. Defoliation Operations: There are currently eight active defoliation projects in II CTZ. Of these projects four were approved by COMUSMACV since the last report. A total of 101 sorties were flown defoliating approximately 14,500 hectares. Five projects are currently being processed through MACV. Of these projects three were submitted since the last report. In addition ground based operations were conducted for base camp and route security.

(b) Riot Control Agent Operations: M7A3 CS grenades were employed in Operations THAYER II, PERSHING, SAM HOUSTON and FARRAGUT. In excess of 34,000 pounds of bulk CS-1 was disseminated in Operation BYRD, THAYER II, PERSHING, SAM HOUSTON, FRANCIS MARION, FARRAGUT AND SUMMERALL. Approximately 2,000 pounds of CN were employed in Operation FARRAGUT. Interrogation of a returnee revealed that he was effectively incapacitated by CS for approximately 15 minutes. However, CS did not force him from cover due to artillery employment on the position. There were two instances of enemy use of RCA during this reporting period.

(c) Flame Operations: Flame weapons and flame field expedient are widely used in II CTZ in base defense plans. These devices require frequent maintenance. Because of the close proximity of friendly troops to the target, the 1st Cav Div (AM) dropped 55 gal drums of napalm on a cave complex using a CH-47 delivery system. Troops withdrew approximately 50-100 meters from the target area during the drop.

CONFIDENTIAL

CONFIDENTIAL

53

AVFA-GC-OT

SUBJECT: Operational Report for Quarterly Period Ending 30 April
1967, RCS CSFOR-57 (U)

4. (C) Logistical Activities:

a. General.

(1) There were no major logistical problems encountered during this period with continued improvement noted in logistic support to combat operations within II CTZ. Primary logistical effort was devoted to Operations: THAYER II, PERSHING, SAM HOUSTON, GATLING I & II, ADAMS, FARRAGUT, BYRD, FRANCIS MARION, and SUMMERALL.

(2) Forward Support Areas (FSAs) supporting above mentioned operations were located as follows:

- | | |
|------------------|-------------------|
| (a) Phan Thiet. | (e) Plei Djereng. |
| (b) Khanh Duong. | (f) Oasis. |
| (c) Hammond. | (g) Le Thanh. |
| (d) English. | |

(3) ACofS, G4 continues to monitor the daily status of stocks on hand at all FSAs; also equipment and supply shortages, deadline rates and medical statistics for units assigned, attached and OPCON to I FFORCEV.

b. Supply.

(1) There are no existing shortages impairing the operational capability of this command. However, several items remain in short supply. These items are as follows:

- (a) Air delivery slings and nets.
- (b) AN/PRC 25 radios.
- (c) 2½ ton trucks.
- (d) Rough terrain forklifts.
- (e) 3 and 10 KW generators.
- (f) Repair parts for generators and aircraft.

(2) Class I, III, IIIA and V supplies have been adequate to support all operations.

(3) The following additions and deletions were made to the ASR during the reporting period.

(a) Additions:

- 1. Detonating cord - M455/456 - March
- 2. Gren, smk, yellow - G945 - March
- 3. Gren, smk, violet - G955 - March
- 4. 175mm projectile - D572 - April

(b) Deletions:

49
CONFIDENTIAL

CONFIDENTIAL

54

AVFA-GC-OT

SUBJECT: Operational Report for Quarterly Period Ending 30 April 1967, RCS CSFOR-65 (U)

1. 40mm (M79) - B568 - March
2. 4.2 inch HE - C704/705 - March
3. 105mm Illum - C449 - March
4. Gren, frag, M26 - G890 - March
5. 2.75 inch HE RKT - H - all - March
6. Signal, gnd, GSP - L310 - March
7. Signal, gnd, RSP, L311 - March
8. Flare, aircraft, para MK24 - L407 - March
9. Detonation cord - M455/456 - March

c. Maintenance.

(1) During this period, Project Counter Teams arrived in II CTZ. One team is operating under the USA Support Command, Qui Nhon and another under the USA Support Command, Cam Ranh Bay. The teams are visiting all I FFORCEV OPCON, attached and assigned units and will purify their PLLs and ASLs. The team is also obtaining accurate density lists, validating outstanding requisitions at all levels and identifying excesses and shortages of repair parts.

(2) The conversion of the 2nd Bn, 8th Inf of the 4th Inf Div was delayed for a time because of a shortage of repair parts and special tools. The 1st Log Comd has processed requisitions for the short items and those that were not filled were placed on a priority requisition to CONUS. Conversion started on 15 April 1967.

d. Medical.

(1) The health of the combat soldier in the II CTZ continues to be excellent. During the period 1 Feb 67 thru 30 April 1967 no significant trends were recorded. Malaria continues to be the most serious threat to the individual soldier; however, February showed a marked decline in the number of reported malaria cases. Plague and cholera have been reported among the civilian population in II CTZ but US combat soldiers have not been effected. This fact exists because of the high sanitary standards of the US troops, the US immunization program, and the quick response of the preventive medicine personnel.

(2) The 91st Evacuation Hospital became operational at Tuy Hoa on 15 April 1967 with a 100 bed facility. The 71st Evacuation Hospital in Pleiku is expected to open within the next 30 days.

(3) Air evacuation continues to be the principle means of transporting sick and wounded from the battlefield to the rear. The 498th Air Ambulance Company evacuated 1,882 US servicemen in February, 2,161 US patients in March and 1,539 in April 1967.

(4) There were only minor occurrences of Hepatitis, heat exhaustion and psychiatric disease reported during the period.

50

CONFIDENTIAL

55

CONFIDENTIAL

AVFA-GC-OT

SUBJECT: Operational Report for Quarterly Period Ending 30 April
1967, RCS CSFOR-65 (U)

e. Transportation.

(1) Tonnages moved during this period amounted to approximately 700,000 s/t.

(2) Land LOCs open and secure to support tactical operations, base camps and 1st Log Comd operations are as follows:

- (a) Highway 19 from Qui Nhon to Pleiku.
- (b) Route QL 19 from junction route 14 to Duc Co.
- (c) Highway 509 from Pleiku to Plei Djereng.
- (d) Highway 14 from Kontum to Duc Lap.
- (e) Route 14b from junction highway 509 to junction QL 19.
- (f) Highway 509 B from Plei Djereng to Plei Trap area.
- (g) Highway 7b from junction highway 14 to Phu Tuc.
- (h) Highway 7b from Cung Song to junction highway 1.
- (i) Highway 21 from junction highway 1 to Ban Me Thuot.
- (j) Highway 6b from junction highway 1 to Le Hai.
- (k) Highway 6b from junction highway 1 (Qui Nhon) to Van Canh.
- (l) Highway 20, 21a and 11 from Phan Rang to Bao Loc.
- (m) Highway 1 from Phan Thiet to I Corps/II Corps boundary.

5. (C) Personnel and Administrative Action:

a. Maintenance of Unit Strengths:

(1) HQ IFFORCEV key personnel and FWMAF senior commanders are shown at inclosure 16.

(2) Authorized and assigned strength of assigned and attached units have been generally satisfactory throughout the reporting period. Headquarters, USARV has been contacted concerning the relatively low strength posture and MOS imbalances of the 54th Signal Battalion. A short fall in MOS 31M (radio relay and carrier attendant) has been experienced and DA has indicated fill action should be completed in May. The present for duty strengths of the OPCON Units have approximated 100% of authorized during the period. Heavy rotational humps within the personnel structure of OPCON units will be experienced particularly in the month of July 1967.

(3) This headquarters will continue to monitor current manpower resources, with a view toward effecting actions necessary to improve or alleviate problem areas.

51

CONFIDENTIAL

CONFIDENTIAL

56

AVFA-GC-OT

SUBJECT: Operational Report for Quarterly Period Ending 30 April
1967, RCS CSFOR-65 (U)

(4) Personnel strengths of assigned attached and operational control units are shown at inclosure 17. Present for duty percentages of assigned strengths of maneuver battalions is shown at inclosure 18.

b. Personnel Management:

(1) Receipt of assignment instructions for personnel nearing rotation continued to be somewhat sporadic. However, new systems of notification have been instituted and USARV, AG, has attempted to improve the timeliness of receipt.

(2) Qualification and motivation of personnel within the assigned, attached and under the operational control of this headquarters continues to be excellent.

c. Civilian personnel:

Civilian personnel management procedures continued to improve. Pay procedures continue to be satisfactory and all local employees are receiving bi-weekly pay. On 7 Jan 67 USARV issued instructions prohibiting the hiring of VN direct hire employees without prior approval of that headquarters. On 28 Jan 67, USARV directed that this headquarters review all positions currently authorized for assigned and attached units and submit justification for all positions required. On 13 April 1967, this headquarters received a new manpower authorization voucher to be further distributed to assigned and attached units. In view of the command wide reduction, this headquarters must reduce the previous authorization of 359 to 201 NLT 30 June 1967. Civilian personnel status of this headquarters is shown below:

- (1) Aid in Kind (AIK) employees auth - 91
- (2) AIK employees on hand 1 Feb 67 - 72
- (3) Released during reporting period - 6
- (4) Released for cause - 2
- (5) Released for individual request - 4
- (6) Transferred - None
- (7) Employed during period - None
- (8) Number of employees on hand 30 Apr: 66

d. Enlisted promotion allocations for assigned and attached units are shown at inclosure 19. Utilization of all allocations is considered excellent. One 13Z E-9 and 2 13B E-7 requisitions were submitted for February erroneously and were subsequently returned to USARV. Three E-7 (13B; 71H; 71N) requisitions submitted for March were returned to USARV. One requisition was returned due to an administrative error in requisitioning procedure; two were returned as a result of the two applicants concerned refusing to sign statements of obligation. The 13Z E-9 allocation requisitioned for April was returned to USARV as a result of an error in requisitioning procedures. All units have been cautioned concerning proper procedures for requisitioning and all unit requisitions will be more closely monitored by this headquarters.

52

CONFIDENTIAL

CONFIDENTIAL

57

AVFA-GC-OT

SUBJECT: Operational Report for Quarterly Period Ending 30 April
1967, RCS CSFOR-65 (U)

e. Development and maintenance of morale:

(1) Morale services within the command continued to improve. The morale of all assigned and attached unit personnel remained excellent throughout the reporting period.

(2) R & R quotas for assigned and attached units were distributed and utilized as shown at inclosures 20 and 21. There were no significant difficulties experienced during the quarter. Those assigned units in III MAF are receiving sufficient transportation allocations from Da Nang.

(3) Awards and decorations approved during the period are at inclosure 22.

(4) Chaplain activities:

(a) In II CTZ, there are 154 US military chaplains.

	<u>ARMY</u>	<u>AIR FORCE</u>
Protestant	105	10
Catholic	31	7
Jewish	1	0
TOTAL	137	17
GRAND TOTAL	154	

(b) Religious services:

1. Protestant services in OPCON units and in combat support and service support units, with the exception of Advisory Teams, are adequate. Advisory Teams must depend on the presence of other US units in the vicinity. The number of Advisory Teams renders regular weekly services by advisory chaplains a practical impossibility.

2. Catholic services in OPCON units are adequate.

3. Jewish services are adequate. Services are conducted by the Jewish Chaplain in 13 locations once a month and in Nha Trang every week on the Sabbath. Lay leaders conduct weekly Jewish services at the 13 locations. Coordination is no problem. One Jewish chaplain assigned to this headquarters has responsibility for II CTZ.

4. The following services are scheduled in Nha Trang:

a. Sunday: 12 Protestant, 11 Catholic.

b. Friday evening: Jewish Sabbath service.

c. Daily: 3 Catholic services.

5. Services are conducted at the following locations:

Hq I FFORCEV	17th Avn Gp	Camp McDermott
54th Sig Bn	Hq NTSAC	5th Special Forces
459th Sig Bn	8th Field Hosp	US Air Force Base

53

CONFIDENTIAL

SECRET

58

AVFA-GC-OT

SUBJECT: Operational Report for Quarterly Period Ending 30 April
1967, RCS CSFOR-65 (U)

6. During the period the following principal Christian and Jewish Holy days were observed: Holy week and Easter, during the week of 19-26 March; Passover, the week of 25-30 April. The Easter Sunrise Service was held on the beach at Nha Trang. Attendance was approximately 500. Chaplain (LTC) Wallace Bennett, I FFORCEV delivered the sermon. The Jewish Passover in Nha Trang united over 300 personnel of Jewish faith from II Corps Tactical Zone. Chaplain (MAJ) Ernest D. Lapp, I FFORCEV, planned and conducted all the ceremonies. The location for the Passover Seders was provided by the Commanding Officer, 8th Field Hospital. The services were held in the I FFORCEV Chapel.

7. The extension and consolidation of the ROK forces TAOR's and the consequent withdrawal of US Infantry units, left five US Artillery Batteries in support of the ROK forces. Chaplain coverage and weekly religious services for these batteries is being provided by the I FFORCEV Chaplain Section.

8. The chaplains, 1st Brigade, 101st Airborne Division were outstanding in providing services for all the combat and combat support units in their areas of operation, to include Artillery, Engineer and Army Aviation units.

9. Personnel changes:

Deputy Staff Chaplain: Chaplain (LTC) Wallace J. Bennett replaced Chaplain (LTC) Robert R. Arms, who departed normal DEROS 14 February 1967.

10. Area Coordination - Religious Activities:

On 6 February 1967, I FFORCEV Regulation 10-4 was published outlining policy and procedures for chaplain area and denominational coverage in II Corps Tactical Zone.

f. Maintenance of Discipline, Law and Order:

(1) Discipline, Law and Order:

(a) Off limits actions: During the quarter Tuy Hoa Village and Tin City in Phu Yen Province and the City of Phan Rang in Ninh Thuan Province were the subject of off limits action. The issues were resolved by placing Tuy Hoa in a modified off limits status, Tin City totally off limits, and Phan Rang on limits with strict enforcement of 1830-0630 hours curfew.

(b) Law and order:

1. Offender statistics for 3d quarter FY 67 for I FFORCEV and OPCON units indicated that class I crimes (serious type) remained approximately at the same level while class II offenses (less serious crimes and violations) increased. Within the class I crimes there was a slight decrease in burglary and housebreaking, larcenies, aggravated assaults, and auto thefts. Primary cause for the rise in class II offenses was the increase in incidents of sex offenses, marijuana, pass violations, off limits and other similar military offenses. The increase in pass and off limit violations can be attributed to strict enforcement measures. The use of marijuana continues as a vexing although not serious problem. CID, together with unit commanders and the Vietnamese

54

SECRET

AVFA-GC-OT

SUBJECT: Operational Report for Quarterly Period Ending 30 April 1967
RCS CSFOR-65 (U)

National Police, are working towards drying up sources and prosecuting those subjects using or selling marijuana.

2. The diversion of military and post exchange supplies into blackmarket channels continues. Commodities being sold on the blackmarket range from truck loads of supplies to individual items such as cameras, TV sets, and radios. Measures taken by civilian authorities to suppress blackmarket activities include proclamations by two province chiefs concerning confiscation of items on the civilian market, and in one province, the formation of a joint blackmarket squad. US suppressive actions include orientation of personnel, increased investigation effort by CID, closer supervision at docks, depots, and exchanges, improved accounting and reporting procedures, cooperation with civilian police, and the establishment of fixed and mobile police check points. Community Relations Committees and Friendship Councils are also being used to educate the local civil officials on the adverse impact of blackmarket on the civilian economy.

(c) Traffic safety program:

1. The establishment of joint highway regulating points on Highway #1 between Dien Khanh vicinity Nha Trang and Vung Ro Bay has effectively controlled convoy movements. An average of 9 convoys pass through the regulating points each day. Traffic regulation between Qui Nhon and Bong Son continues to be an efficient operation.

2. The high rate of traffic accidents remains a problem throughout Vietnam. Within II CTZ, 38 Vietnamese and 9 US personnel were killed as the result of traffic accidents during the period of this report. Military vehicles of 2 1/2 ton or larger were involved in 62% of all fatal accidents. The primary causes of the high fatality rate are speed excessive for conditions, failure to yield, following too close, unsafe passing, and other careless acts. Narrow roadways in poor condition, the increased density of vehicles, and the erratic behavior of many of the Vietnamese motorists and pedestrians increase the potential for accidents. Defensive driving techniques are being stressed along with education and strict enforcement.

(2) Traffic Control and VIP Escorts:

(a) A message received from MACVJ1, on 5 Feb 67, subject: Police Escorts and Traffic Control, admonished US forces Police for escorting VIP's and directing traffic on public streets and highways. It pointed out that assumption of this role was in violation of MACV and GVN policy. In the future, Vietnamese National Police will be requested to escort VIP's and direct traffic along route of travel as required. OPCON units and 272d MP Company were notified of this policy by I FFORCEV message B-1449, dtg 180742Z Feb 67.

(b) Compliance with existing policies should not unduly influence or reduce security of VIP's since trail security by US personnel is authorized. There were 11 visitors to Headquarters, I FFORCEV during the period that required VIP security.

(3) Joint Mobile and Fixed Check Points:

Mobile and fixed police check points were established in and around Nha Trang to determine the feasibility of establishing the opera-

SECRET

60

AVFA-GC-OT

SUBJECT: Operational Report for Quarterly Period Ending 30 April
1967, RCS CSFOR-65 (U)

tions throughout II CTZ. The employment was oriented to resource and population control, and the prevention of blackmarket activities as well as normal police enforcement. The check points are composed of VNP, ROK, ARVN and US MPs. Two Mobile check points operate from 1800 to 0600 hours and 0600 to 1800 hours daily. Mobile check points were established within the urban area of Nha Trang along high density routes on a random basis to avoid establishing a pattern of operations. No fixed check points operating 24 hours daily were established on the highways entering the city; fixed points were used because access is limited to one north-south road. Civilian and military vehicles of all forces are halted on a selective basis, searched for contraband, and examined to determine if the vehicle and personnel are properly dispatched and/or documented. Vehicles with cargo that cannot be accounted for are impounded by the force concerned; individuals without proper identification are detained by Military Police or National Police. Daily activity reports are submitted by each member of the team to the Chief, Khanh Hoa Province National Police, for analysis and reporting to representatives of each force. The representatives hold periodic meetings to analyze the effectiveness of the check points and devise solutions or make changes to enhance the operation. Thus far, this method of resource control has proven effective; Pleiku and Qui Nhon areas are now instituting similar programs on a limited basis. These operations also give the added advantages of on the job and supervised training for the National Police and ARVN Military Police. Care is taken to avoid usurping the prerogative of the National Police. There has been complete cooperation in this area.

(4) Police Officer's Conference:

Khanh Hoa Police Officer's conference, hosted by the various police agencies on a rotating basis, was held in March and April. Representatives of the Air Police, USAF, Vietnamese National Police and Customs, ARVN, ROK, and US Military Police, OCO (USAID) Custom and Public Safety Advisor, PMS I FFORCEV, and Nha Trang Sub Area Command were in attendance.

(5) Prisoners of War:

(a) Camp construction:

1. A letter from MACV J15, dated 14 Feb 67, subject: Prisoner of War Camp Construction, indicated that funds for the PW camp construction and expansion had been programmed from CY 66 monies and that GVN fiscal policies required liquidation on or before 31 March 1967. The short period of time between the original allocation of the money and the deadline for liquidation made it impossible to comply with the 31 March deadline as contract negotiations had not yet started. A letter was forwarded to MACV requesting assistance at JGS level in obtaining a 60 day extension of the deadline. DSA, II Corps was requested to press for extension of deadline through ARVN channels. On 25 March 1967, COMUSMACV notified Hq, I FFORCEV that GVN had granted an extension on expenditures of monies until 31 May 1967.

2. Camp construction at Phu Tai (near Qui Nhon) PW camp began with site preparation in late February; approximately 45000 cubic yards of fill was required before building construction could commence. The fill operation was accomplished by the 6th ARVN Engineers. Bids for the contracts were let on 20 March 1967. The low bidder refused to sign the notice to proceed and the second low bidder was declared unacceptable.

56

SECRET

SECRET

AVFA-GC-OT

SUBJECT: Operational Report for Quarterly Period Ending 30 April 1967
RCS CSFOR-65 (U)

Successful bidding took place on 3 April 1967; work will be completed using a combination of ARVN Engineer units and civilian contractors. Construction is proceeding satisfactorily and a target date of 25 May 1967 has been established for completion of the project.

3. Ground preparation for the Pleiku PW camp expansion was completed in late February. Materials arrived at the site and construction began in early March. All buildings in the prisoner compound are erected (as of 15 April 1967, the project was approximately 95% completed with opening date set for 20 April 1967). Since that date, there appears to be a general reduction in the effort to complete the project; little progress has been made and a 15 May 1967 completion date is now estimated.

(b) Camp Quarantine:

An outbreak of meningitis among the prisoners at the Pleiku camp caused a quarantine from 18 March to 31 March 1967. On 3 April 1967, another case of meningitis was diagnosed and the camp was again quarantined. The closure was extended until 28 April 1967 because of further cases. In all, seven cases of meningitis were reported with two deaths attributed to the disease. During the quarantine period, OPCON units were instructed to hold PW in collecting points until MACV/JGS were able to complete arrangements permitting evacuation to other Corps PW camps. PW released from hospitals were ordered returned to the major unit of capture until such time as the II Corps PW camp is reopened or other evacuation arrangements could be made. A review of capacity of OPCON collecting points indicated that under emergency conditions approximately 400 PW could be accommodated with potential for another 100 at the 1st Cav Div (AM) base camp cage, providing additional military police support was furnished. Permission was obtained from JGS to evacuate 200 PW to III Corps PW camp providing G2, II Corps screened the PW for intelligence value and authorized the evacuation. One hundred seventy-five PW from 1st Cav Div (AM) and 25 PW from 9th Inf Div (ROK) were evacuated to III Corps under this procedure. A 1st Cav Div (AM) operation within I Corps area resulted in capture of over 150 PW; 153 of these PW were evacuated to I Corps PW camp through arrangements with PM, III MAF. The evacuation of the 353 PW eased the situation in PW collecting points and reduced population to a manageable level. Consideration to retaining PW in OPCON unit collecting points included adequate provisions for care, humane treatment, and security. While the potential of enemy attack with possibility of death or injury to prisoners existed, the risk had to be assumed in the face of evacuation restrictions.

(c) Classification Change:

A message received from MACV concerning classification of PW has expanded the definition of PW to include guerrilla, self-defense force, and secret self-defense force. A staff study was made to determine the impact of expanded definition of PW facilities and to revise the capture rate. It was concluded that US input to the PW camp should increase from an average of 4 per day to approximately 8 per day and for every 100 detainees captured, 13 would become PW. The increase in capture rate and the high input rate will not adversely effect the overall capacity of PW camps at this time. The expansion of the Pleiku camp and construction of the camp at Phu Tai, when completed, will be adequate to meet requirements through CY 67, providing a 1500 to 2500 population maximum is established. In the event maximum capacity is reached, MACV/JGS will be requested to transfer PW to less populated camps in other corps areas.

SECRET

AVFA-GC-OT

SUBJECT: Operational Report for Quarterly Period Ending 30 April 1967
RCS CSFOR-65 (U)

(d) Escape Plot:

1. On 13 April 1967, intelligence information was received that a mass breakout was planned by PW at the II Corps Combat Captive (PW) Camp, Pleiku. The planned breakout was scheduled for period 15-19 May 1967 to commemorate the birthday of Ho Chi Minh, to show gratitude to "Uncle Ho" and gain international recognition. Prior to breakout PW were to agitate by complaining of insufficient food, water, poor medical treatment, and lack of clothing; also, they would agitate for additional privileges. An informal prisoner organization of companies and platoons was established to facilitate control and for the gathering of intelligence information. Twenty-two alleged leaders of the plot were removed from the camp and are now awaiting transfer to another Corps area.

2. As an immediate emergency measure, a US rifle company from 4th Inf Div was assigned to supplement external security measures; this unit was later replaced by a US tank platoon. II Corps has taken additional protective measures to include sentry dogs with handlers patrolling the outer fence during darkness, increased security force in guard towers and emplacement of additional Claymore mines and barriers in the critical perimeter area. Gun and Flare ships have been alerted and are exercised twice a week. An additional RF platoon was assigned a security mission with an AO in and around the nearby village of Plei Rah. The camp commander has ordered a minimum of three weekly shakedowns of PW and the compound in an effort to locate contraband items.

3. As of this date the situation appears under control; however, increased vigilance will be required to detect and prevent future plots of this same nature. The geographical location of the camp presents a lucrative target for the enemy.

(e) Deficiencies noted in PW Camp Operations:

1. During the past four months a physical security survey was conducted of the II Corps Combat Captive (PW) Camp and a number of staff visits were accomplished. Deficiencies pointed out to the camp administrators, II Corps staff, and advisory personnel, included the inadequate security of the recreation yard, lack of prisoner work projects, the inadequacy of the prisoner informant net, the apparent complacency on part of camp personnel regarding security, the possibility of potential trouble from PW due to ideological training; the laxity of guard personnel in performing duties; the need for strict prisoner discipline, and the need for an aggressive program of psychological indoctrination. A letter pointing out deficiencies in camp operations was dispatched by General Larsen to the II Corps Commander.

2. The camp was initially designed for a capacity of 500 PW; the in-camp population as of 30 April 1967 was 1799 prisoners. This situation has caused extreme congestion and is over taxing the mess, sanitation, and medical facilities. The outbreak of meningitis in March which continued through the middle of April is attributed to the congested conditions. Tentage was erected to relieve the congestion in the barracks, but offered only partial relief. Expansion of the existing facilities and construction of the camp at Qui Nhon has been aggressively pushed from I FFORCEV and the Advisory level since September 1966. At this time the project capture rate indicated the capacity would be exceeded by the end of 1966. Although the camp as originally built could adequately hold

63

CONFIDENTIAL

AVFA-GC-OT

SUBJECT: Operational Report for Quarterly Period Ending 30 April 1967
RCS CSFOR-65 (U)

1200 PW, it does not have facilities for internment beyond that capacity without down-grading security and control. While it is fully realized that the PW program is under GVN control, it is also realized that adverse publicity resulting from failures in PW camp operations will be directed primarily at the United States Government. Therefore, this command has, and will continue, an active monitorship of these operations to assure full compliance with the spirit of the Geneva Convention Relative to Treatment of Prisoners of War.

(f) Population:

The II Corps Combat Captive (PW) camp population for the period increased from 998 to 2004. This was a net increase of 1006 PW; 16 from Operation BYRD; 775 from Operation PERSHING; 18 from Operation SAM HOUSTON; 66 from Operation THAYER II; 13 from Operation ADAMS; 19 from Operation FARRAGUT; 2 from Operation GERONIMO I (these were hospital patients); 56 from ROK Forces; and 80 from ARVN units. Twelve PW died during the period. Thirty-five female PW are in camp and 15 were transferred to I Corps Captive (PW) camp. Twelve PW were repatriated by GVN.

g. Headquarters Internal Arrangement:

(1) The following listed facilities have been constructed and/or completed during the reported period.

(a) Three each 20' X 48' quonset type troop billets. Billets are being utilized to house non-commissioned officers and mess personnel.

(b) Security screen over electrical generating plant fuel storage tanks.

(c) Security fence around the 69th Signal Detachment (east side of Beach Road).

(d) Security fence around the I Field Force Vietnam Compound.

(e) Improved mess hall grease leaching field.

(2) The following facilities have been requested.

(a) Two each 20' X 100', two-story, tropicalized, wooden-framed troop billets. Construction is proposed for the newly acquired parcel of land located immediately to the rear of the Villa De France. Construction is pending the administrative action of the Post Engineer. Additional Troop billets are urgently required due to extreme overcrowding currently being experienced in the existing troop billets. Troops are authorized, by USAMACV Construction Bulletin 415-2-10, 70 square feet per man. However, there is only 39 square feet per man now available. This adverse situation shows no indication that it will diminish.

(b) Two each, 20' X 120', two-story, wooden-frame administrative office buildings. A survey of existing office space reveals critical overcrowding is being experienced by all headquarters administrative/operational sections. Construction is pending approval.

CONFIDENTIAL

CONFIDENTIAL

64

AVFA-OC-OT

SUBJECT: Operational Report for Quarterly Period Ending 30 April 1967
RCS CSFOR-65 (U)

action by higher headquarters. Ample real estate is available within the headquarters complex to construct requested buildings.

(c) One each security guard post to be located at the exit gate (SE corner of the compound.).

(3) The following facilities are currently under construction.

(a) Improved classified waste incinerator.

(b) Headquarters and Headquarters Company Day room.

(4) The following facilities will be constructed in the near future.

A 40' X 65' compound theater. This is to eliminate use of the mess hall as a theater and also to provide a class room for training purposes.

(5) Miscellaneous.

(a) A building rescreening project has been completed.

(b) The compound repairs and utilities organization (PA&E) has been directed to reduce the total number of weekly hours of employees to 5 1/2 days per week (60 hours). This has been necessitated in order to curtail expenditure of obligated funds.

(c) R&U employees are experiencing increased difficulty with the existing KUBOTA electrical power generators due to faulty material. To insure continued and uninterrupted power for this complex a 350 kw mobile generator has been positioned on the compound for use in an emergency.

(d) The following parcels of land have been acquired for use by this headquarters.

1. A parcel of land, 55 X 96 meters, located behind the Villa de France (SW corner of the compound).

2. A parcel of land, irregular in shape, 50 X 90 meters, located immediately north of the compound.

3. These two parcels of land are to be used for construction of troop billets and establishment/relocation of I Field Force Vietnam maintenance facilities from their present location at Camp McDermott.

(e) Continual efforts are being made to repair/improve existing facilities essential to this headquarters.

(6) Intelligence.

(a) A new, revised security pass system for all indigenous laborers has been implemented. This revision was required in order to ensure denial of unauthorized personnel into the compound.

60

CONFIDENTIAL

CONFIDENTIAL

63

AVFA-GC-OT

SUBJECT: Operational Report for Quarterly Period Ending 30 April 1967
RCS CSFOR-65 (U)

(b) R&U Manager submits an attendance roster to this office, which reflects status of all employees.

(7) Operational Activities:

(a) Work is progressing to install four each house trailers to be located within the I Field Force Vietnam Forward CP area.

(b) The I Field Force Vietnam (Headquarters) Physical Security Plan is in process of being revised and up-dated to conform to realistic changes occurring since it was originally published.

(c) The 297th Trans Co (CAR) continues its superb support of this headquarters.

(8) Inspections:

Headquarters Commandant has conducted the required monthly inspections of the attached 297th Trans Co (CAR). Inspections have, without exception, been favorable.

(9) Psychological Operations:

The Headquarters Commandant has been designated by the Chief of Staff, Headquarters, I Field Force Vietnam, to coordinate a civic action program whereby this headquarters will sponsor a fund raising campaign to aid the local Vietnamese Boy Scout movement. Fund raising has been progressing in an outstanding manner.

6. (C) Artillery:

a. Headquarters Battery, 8th Battalion, 26th Artillery (Target Acquisition) completed deployment of its six AN/MPQ-10A radar sections and two meteorological sections during early February 1967. The AN/MPQ-10A sections are employed primarily in static positions in the defense of critical installations. The battery's three survey sections are rapidly extending survey control through the II CTZ and a corps survey information center has been established at Camp Townes, Qui Nhon.

b. Battery B, 29th Artillery (Searchlight) received the 23 inch Xenon searchlight on a two for one basis for the old 30 inch carbon-arc lights. The new lights are jeep mounted and have an infrared capability. Conversion of all searchlight sections in the field was completed by the middle of February.

c. The 1st Battalion, 92nd Artillery (155mm howitzer towed) arrived in-country and was attached to the 52nd Artillery Group for employment in the central highlands. The advance party arrived on 26 Feb 67 and established the battalion base camp at Artillery Hill, Pleiku. The main body arrived at Qui Nhon aboard the MISS AMERICA and off-loaded on 11 March 1967. Since becoming operational in March the battalion has provided artillery support of 4th Inf Div and ARVN elements in the highlands and the 1st Cav Div (AM) in Binh Dinh Province.

d. Also arriving at Qui Nhon on the MISS AMERICA was the 4th Battalion, 60th Artillery AWSP, (twin 40mm) with its attached Battery E, 41st Artillery (quad 50 cal MG). The 4th Battalion, 60th Artillery first established its base camp at Phu Cat Air Force Base but later moved to Camp Townes near Qui Nhon. Since becoming operational, the battalion has supported all major US maneuver forces in every major US operation in II CTZ.

61

CONFIDENTIAL

CONFIDENTIAL

66

AVFA-GC-OT

SUBJECT: Operational Report for Quarterly Period Ending 30 April 1967
RCS CSFOR-65 (U)

It is the only AW battalion in II CTZ and is attached to 41st Artillery Group.

e. The 6th Battalion, 32nd Artillery (8 inch SP) arrived during March 1967. The advance party closed on 10 March with the main body following on 15 March. Unit equipment and impedimenta was received shortly after and the battalion was operational by 1 April 1967. The battalion base camp was established at Tuy Hoa and its firing batteries are employed along the coastal regions of II Corps primarily in support of the Cap ROK Inf Div and 9th ROK Inf Div. Command and control has been retained by I Field Force Vietnam Artillery.

f. An artillery evaluation team was organized on 13 March 1967 by I Field Force Vietnam Artillery. The team members were drawn from units in the field and were specifically chosen for their experience in particular fields. Evaluation of battery size units included fire direction, observed fire, firing battery and communications procedures. Various trends of weak and strong points were uncovered and evaluated allowing appropriate action to be taken to improve the degree of training of artillery units and to decrease the number of artillery incidents.

g. Battery G, 29th Artillery (Searchlight) arrived in-country in March and was preparing for deployment when it was diverted by COMUSMACV to I CTZ. On 18 March 1967 the battery went under OPCON of III MAF and moved its base camp to Da Nang.

h. On 23 March 1967 Colonel Jerry F. Dunn assumed command of I Field Force Vietnam Artillery vice Brigadier General Edward H. deSaussure Jr.

i. On 2 April 1967 the 7th Battalion, 13th Artillery; 4th Battalion, 60th Artillery; and Battery E, 41st Artillery began relocating their base camps from Phu Cat Air Force Base to Camp Townes near Qui Nhon.

j. Effective on 9 April 1967, a switch took place between Battery B, 1st Battalion, 30th Artillery and Battery C, 6th Battalion, 16th Artillery. Battery B, 1st Battalion, 30th Artillery, which had been attached to the 1st Bde, 101st Abn Div for some time, was returned to the control of its parent unit for employment in the PERSHING AO. Battery C, 6th Battalion, 16th Artillery, a separate battery, was detached from the 1st Cav Div (AM), and attached to the 1st Bde 101st Abn Div. Both are 155mm towed howitzer batteries.

k. Effective 13 April 1967, the 3rd Battalion, 18th Artillery, minus Battery A was detached from I Field Force Vietnam Artillery and attached to Task Force Oregon for employment in Operation OREGON. Battery A, 3rd Battalion, 18th Artillery was attached, in place, to the 1st Battalion, 30th Artillery and continues support of Operation PERSHING.

l. On 20 April 1967, Colonel William O. Quirey assumed command of I Field Force Vietnam Artillery vice Colonel Jerry F. Dunn. A change of command ceremony was held at the 5th Special Forces Group (Airborne) Quadrangle, Phu Trang. Massed colors from the 52nd Artillery Group and the battalions attached to I Field Force Vietnam Artillery were in attendance. Captain Herbert D. Wells, Commanding Officer, Headquarters Battery, I Field Force Vietnam Artillery, was commander of troops.

62

CONFIDENTIAL

CONFIDENTIAL

67

AVFA-GC-OT

SUBJECT: Operational Report for Quarterly Period Ending 30 April 1967
RCS CSFOR-65 (U)

m. On 22 April 1967 the I Field Force Vietnam Artillery, Fire Support Element (FSE) became operational. The FSE operates around the clock and is located in the I Field Force Vietnam. Tactical Operations Center.

n. The 41st Artillery Group arrived in-country during April 1967 and was attached to I Field Force Vietnam Artillery. The Group became operational effective 280001H April 1967 when it relieved the Headquarters, I Field Force Vietnam Artillery, Forward, Qui Nhon, which was disbanded. The 41st Artillery Group established its base camp at Camp Townes, Qui Nhon and took over the facilities and communications of the forward headquarters it replaced. The Group, with 3 battalions and 4 separate batteries attached, has a mission of general support of the II CTZ and is generally employed in the north-eastern, coastal portion of the Corps zone.

o. On 30 April 1967, I Field Force Vietnam Artillery lost operational control of two of its four AN/MPQ-4A radar detachments. The 235th and 238th Radar Detachments (countermortar) moved by Air Force C124 to Da Nang and went under OPCON of the III MAF for employment in I CTZ.

p. Artillery units assigned or attached to I Field Force Vietnam during the reporting period were:

(1) Non-divisional:

Hq, I Field Force Vietnam Artillery (Forward Command
Post located at Dong Ha)

41st Artillery Group

52d Artillery Group

3d Battalion, 6th Artillery (105mm)(SP)

7th Battalion, 13th Artillery (105mm) (T)

6th Battalion, 14th Artillery (175mm/8-inch) (SP)

3d Battalion, 18th Artillery (175mm/8-inch) (SP)

5th Battalion, 27th Artillery (105mm)(T)

1st Battalion, 30th Artillery (155mm)(T)

6th Battalion, 32d Artillery (8-inch)(SP)

1st Battalion, 40th Artillery (105mm)(SP)

1st Battalion, 44th Artillery (AWSP)

4th Battalion, 60th Artillery (AWSP)

1st Battalion, 92d Artillery (155mm)(T)

2d Battalion, 94th Artillery (175mm)(SP)

Headquarters Battery, 8th Battalion, 26th Artillery
(Target Acquisition)

63

CONFIDENTIAL

CONFIDENTIAL

68

AVFA-GC-OT

SUBJECT: Operational Report for Quarterly Period Ending 30 April
1967, RCS CSFOR-65 (U)

Battery B, 6th Battalion, 27th Artillery, (175mm SP)
(attached to 2d Battalion, 94th Artillery)

Battery B, 29th Artillery (Searchlight)

Battery G, 29th Artillery (Searchlight)

Battery E, 41st Artillery (MG), (attached to 4th
Battalion, 60th Artillery)

(2) Divisional:

1st Cavalry Division Artillery (Air Mobile)

2nd Battalion, 17th Artillery (105mm T) (attached)

2nd Battalion, 19th Artillery (105mm T)

2nd Battalion, 20th Artillery (ARA)

1st Battalion, 21st Artillery (105mm T)

1st Battalion, 77th Artillery (105mm T)

4th Infantry Division Artillery

5th Battalion, 16th Artillery (155mm/8-inch SP)

6th Battalion, 29th Artillery (105mm T)

4th Battalion, 42nd Artillery (105mm T)

3rd Brigade, 25th Infantry Division

2nd Battalion, 9th Artillery (105mm T)

1st Brigade, 101st Airborne Division

2nd Battalion, 320th Artillery (105mm T)

Battery C, 6th Battalion, 16th Artillery (155mm T)
(attached)

q. Artillery Statistics for reporting period:

(1) Missions fired:

	<u>FEBRUARY</u>	<u>MARCH</u>	<u>APRIL</u>
H&I	55,322	51,372	55,250
OTHER	8,834	19,593	22,215
OBSERVED	5,630	8,463	9,105
UNOBSERVED	<u>58,526</u>	<u>62,502</u>	<u>64,360</u>
TOTAL	64,156	70,965	77,465

⁶⁴
CONFIDENTIAL

69

CONFIDENTIAL

AVFA-GC-OT

SUBJECT: Operational Report for Quarterly Period Ending 30 April
1967, RGS CSFOR-65 (U)

(2) Ammunition Expended:

	<u>FEBRUARY</u>	<u>MARCH</u>	<u>APRIL</u>
(a) 2.75	8,013	24,193	26,218
(b) 105 HE	153,843	176,093	135,178
105 ILL	9,805	5,098	6,660
105 WP	12,554	50,856	45,706
105 SMK	5,408	4,831	6,308
105 OTHER	<u>350</u>	<u>677</u>	<u>1,983</u>
TOTAL	181,960	237,555	195,835
(c) 155 HE	30,295	19,775	20,413
155 ILL	1,433	886	847
155 WP	1,244	1,327	3,537
155 SMK	647	446	681
155 OTHER	<u>37</u>	<u>3</u>	<u>9</u>
TOTAL	33,656	22,437	25,487
(d) 8 inch HE/LL	738	13,634	13,432
(e) 175mm HE	12,894	24,603	23,284

7. (C) Engineer

a. General: Company C, 4th Engineer Battalion was redeployed to the III Corps Tactical Zone during the period covered by this report to provide engineer support to the 3rd Brigade, 4th Infantry Division. Company C, 4th Engineer Battalion was deployed to III CTZ in lieu of Company D, 65th Engineer Battalion as originally planned.

b. The bulk of the effort of the engineer section during the reporting period was devoted to the planning, coordination and supervision of the engineer combat support provided by the 18th Engineer Brigade units in support of I FFORGEV, ROK, and ARVN operations. Tactical operations supported during the period were SAM HOUSTON, FRANCIS MARION, BYRD, PERSHING, LE JEUNE, ADAMS, FARRAGUT, SUMMERALL, OREGON, GATLING I, GI JAC KYO, and BAC BINH VUONG 802. Engineer combat support effort expended by units of the 18th Engineer Brigades in support of current or future tactical operations included:

(1) Phu Tuc Airfield (BQ 490590). This project encompassed lengthening the existing runway to 3500 feet (C-130 capable), construction of parking area for five C-130 aircraft, surfacing runway and parking apron with T-17 membrane, clearing areas for a F-1 and for parking for three air-mobile companies. Work was accomplished by elements of the 20th Engineer Battalion. The project was completed on 10 March 1967.

65
CONFIDENTIAL

CONFIDENTIAL

30

AVFA-GC-OT

SUBJECT: Operational Report for Quarterly Period Ending 30 April
1967, RCS CSFOR-65 (U)

(2) Cung Son Airfield (BQ 808424). This project involved extending the existing runway to accommodate C-123 aircraft, construction of parking area for five aircraft and surfacing the runway and parking apron with T-17 membrane. Elements of the 39th Engineer Battalion returned to the site on 25 Feb 67. Project was completed on 12 April 1967.

(3) Nha Trang Bypass. This project is a joint US-ARVN engineer project to construct an all-weather two-way CL-35 by-pass road around the city of Nha Trang. Elements of the 14th Engineer Battalion and elements of the ARVN 203rd Engineer Battalion continue bridge and culvert replacement and widening of the road. Current estimated completion date is 1 June 1967.

(4) Tuy Hoa Tactical Road Net. Construction of this road net in the Tuy Hoa Valley is the responsibility of the 29th Engineer Battalion and the ARVN 612th Engineer Company.

(5) Operation BYRD. One platoon of the 14th Engineer Battalion continues to provide general engineer support to the 2nd Bn, 7th Cav, 1st Cav Div (AM) conducting Operation BYRD. Elements of the ARVN 203rd Engineer Battalion supported with US equipment and material continue to repair and replace damaged bridging on Route 8B between Phan Thiet and Thien Giao (AN 870252).

(6) Operation FARRAGUT. Company B, 87th Engineer Battalion completed upgrading of the existing C-130 airfield at Song Mao (BN 270449) on 23 Feb 67. Scope of the project consisted of upgrading the runway and parking apron and surfacing with M8A1 landing mat. In addition, facilities were constructed for a FSA and parking for three airmobile companies. Elements of the 14th Engineer Battalion in support of the 1st Bde, 101st Abn. Div provided engineer support to open QL-1, on an expedient basis, to CL-18 traffic between Phan Thiet and Phan Rang. Opening of this portion of QL-1 was completed on 21 Feb 67.

(7) Extension of Route 509B. The initial scope of this project included the construction of a one lane CL-12 road with turnouts from vicinity of YA 741503 to vicinity of YA 665555 and the possible construction of a C-130 forward area medium lift airfield. The scope of the project was changed to the construction of two-way, dry-weather, CL-31 road. Construction of the road was completed on 7 Feb 67. A decision was made not to construct the C-130 airfield.

(8) Oasis Airfield. This project encompasses the rehabilitation of the existing T-17 membrane C-130 airfield at Oasis. Scope of the project includes removal of the membrane, recompaction and reshaping of the runway and turnarounds. MX-19 landing mat has been allocated and is being installed on the parking apron and taxiways. T-17 membrane removed from the runway has been installed on the helicopter parking areas. Estimated completion date for this project is 1 May 1967. Oasis airfield will be used in support of Operation FRANCIS MARION and future operations in the highlands.

(9) Khanh Duong Airfield. This project involved the construction of an all-weather C-130 capable airfield, an FSA complex and dust free parking for three airmobile companies. This airfield is being utilized to support Operation SUMMERALL. M8A1 landing mat was installed on the runway turnarounds, taxiways, and parking apron. Two companies from the 14th Engineer Battalion moved to Khanh Duong on 15 Feb 67. Project was completed on 26 March 1967. In an effort to eliminate the "pumping of

66

CONFIDENTIAL

91
CONFIDENTIAL

AVFA-CC-OT

SUBJECT: Operational Report for Quarterly Period Ending 30 April
1967, RCS CSFOR-65 (U)

finer" from the runway through the M8A1 matting, such as occurred at English Airfield, the base course was treated with an asphalt cutback (MC-2), burlap was laid over the asphalt and a second application of asphalt cutback was applied to the burlap. The M8A1 matting was then installed on top of the asphalt treated burlap. Evaluation of the effectiveness of this treatment has not been completed.

(10) Duc Lap Airfield. The scope of this project included the construction of a new C-130 capable, all-weather (T-17 membrane) airfield with parking facilities for five aircraft. The airfield will be utilized for resupply of the Duc Lap CIDG Camp and to support future tactical operations in western Quang Duc Province. Elements of the 20th Engineer Battalion initiated construction at Duc Lap on 2 Feb 67. This project was completed on 6 April 1967.

(11) ARVN Operation BAC BINH VUONG 802. This operation was designed to open QL-1 to CL-18 traffic between Tuy An (vic of junction of QL-1 and Route 6B) and Song Cau. Elements of the 612th ARVN Engineer Company assembled spans of Eiffel bridge and repaired piers on the Ngon Son Bridge across the Song Cai River. One span of Eiffel bridge was lifted into place on 28 Feb 67 by a CH-54 helicopter from the 1st Cav Div (AM). The remaining Eiffel spans were lifted into place on 28 March 1967. The Ngon Son Bridge was completed and opened to traffic on 18 April 1967.

(12) Qui Nhon Airfield. Elements of the 45th Engineer Group initiated repair of the southern 1000 feet of the Qui Nhon airfield on 12 Feb 67. Repair consisted of removing and recompacting the base and the application of a two inch hot mix asphalt wearing surface. Repairs were completed on 22 Feb 67.

(13) English Airfield. On 6 Feb 67, Company B, 35th Engineer Battalion began repair of the subgrade and M8A1 landing mat on the runway of English airfield. Approximately 2200 feet of the runway was reworked and surfaced with new M8A1 landing mat. Damage to the runway resulted from the pumping of soil through the matting under sustained C-130 traffic during continuous rains. Repairs were completed on 26 Feb 67. This airfield is being utilized in support of Operation PERSHING.

(14) Van Canh Airfield. Repairs to the damaged T-17 membrane runway and parking apron at Van Canh were initiated by elements of the 19th Engineer Battalion on 8 Feb 67. Repairs consisted of removal of approximately 1400 feet of membrane from the runway, removal of membrane from the parking apron and taxiways, improvement of the airfield drainage system, reshaping and compaction of the runway and parking apron and reinstallation of the membrane. Completion date for this project was 9 April 1967.

(15) Song Lai Giang River Vicinity of Bong Son. In support of Operation PERSHING, elements of the 45th Engineer Group constructed an earth causeway across the major portion of the Song Lai Giang River. Construction of the causeway was completed on 1 April 1967. Installation of a 210 foot float bridge on the causeway was initiated and completed on 24 April 1967. The construction of the causeway and float bridge will permit the movement of armor to the area south of the Song Lai Giang River. This expedient crossing is intended for dry weather use only and the float bridge will be removed in September 1967 prior to the onset of the monsoon season.

CONFIDENTIAL

CONFIDENTIAL

72

AVFA-GC-OT

SUBJECT: Operational Report for Quarterly Period Ending 30 April
1967, RCS CSFOR-65 (U)

(16) Operation OH JAC KYO. In support of the ROK Operation OH JAC KYO, designed to join the TAOR's of Capital ROK Infantry Division and the 9th ROK Infantry Division, the 217th ARVN Float Bridge Company installed a float bridge across the Song Cai River on Route QL-1 vicinity of the junction of Routes QL-1 and 6B. Installation of the bridge was completed on 22 March 1967.

(17) Operation SUMMERALL. Elements of Company A, 326th Engineer Battalion, organic to the 1st Bde, 101st Abn Div repaired and re-opened the abandoned C-7A airfield at Buon Mi Ga (BP315845) in conjunction with Operation SUMMERALL. Engineer equipment was heli-lifted to the site and work was initiated on 5 April 1967. Repairs were completed and the airfield opened on 10 April 1967. Elements of the 14th Engineer Battalion supporting Operation SUMMERALL opened Route 9B from Route 21 for approximately 32 kilometers to the vicinity of BQ 765160. In addition, three bridges on Route 21 between Duc My and Khanh Duong airfield were replaced with semi-permanent bridges in conjunction with the maintenance of this portion of Route 21.

(18) Upgrading of Route 19 from Pleiku to Qui Nhon. Elements of the 45th and 937th Engineer Groups reinforced existing bridges and constructed by-passes on Route 19 between Pleiku and Qui Nhon to accommodate the movement of armor and supporting vehicles. Upgrading to CL-78 was completed on 18 March 1967.

(19) Extension of Route 19. In support of Operation FRANCIS MARION, elements of the 4th Engineer Battalion extended Route 19 west from Duc Co to approximately 1 1/2 kilometers from the Cambodian border. The road is capable of sustaining one-way Class 50 and two-way Class 34 traffic during dry-weather. Construction was initiated on 3 April and completed on 7 April 1967.

(20) Operations LE JEUNE and OREGON. Elements of the 8th Engineer Battalion supporting the 1st Cav Div (AM) in Operation LE JEUNE constructed an assault type C-7A airfield at Duc Pho (vic BS 813835) in southern Quang Ngai Province. The C-7A airfield was completed on 8 April and work was immediately initiated to extend the runway to meet the criteria for C-123 aircraft. Extension of the runway was completed on 12 April 1967. On 12 April 1967, the 39th Engineer Battalion (-) departed Vung Ro by sea for Duc Pho. The mission of the 39th Engineer Battalion, which became OPCON to III MAF on 22 April 1967, included construction of an access road from the South China Sea to Duc Pho, the upgrading of the C-123 airfield at Duc Pho to C-130 all-weather capability, and combat engineer support for elements engaged in the conduct of Operation OREGON. A pioneer road from the beach to Duc Pho was opened on 23 April 1967. Work continues on road improvement.

(21) Route Upgrading. Elements of the 937th Engineer Group are currently engaged in maintaining and upgrading the following roads:

- (a) Route 19 from Route 14 to Duc Co.
- (b) Route 509 from Route 14 to Route 509B.
- (c) Route 14B from Route 19 to Route 509.

Elements of the 45th Engineer Group are currently maintaining and upgrading

68

CONFIDENTIAL

73

CONFIDENTIAL

AVFA-GC-OT

SUBJECT: Operational Report for Quarterly Period Ending 30 April 1967
RCS CSF -65 (U)

Route QL-1 to MACV standards from Qui Nhon to English Airfield.

(22) Paving of Route QL-1. Elements of the 35th Engineer Group initiated the paving of QL-1 on 15 March 1967. The scope of the project includes paving from Ba Ngoi (BP 975174) to Dien Khanh (BP 939550). The project is divided into three phases as indicated:

(a) Phase I: My Ca turn off north to Dong Ba Thin (15 March - 24 April 1967).

(b) Phase II: My Ca turn off south to Ba Ngoi (25 April - 24 June 1967).

(c) Phase III: Dong Ba Thin to Dien Khanh (25 June - 1 December 1967).

(23) Phu Nhon Airfield. Elements of the 937th Engineer Group initiated repairs of Phu Nhon airfield on 7 March 1967. Project included removal of T-17 membrane, compaction, shaping, and replacement of membrane. Project was completed on 22 March 1967.

(24) Cheo Reo Airfield. Construction of an asphalt (double surface treatment) C-130 runway at Cheo Reo was completed by ARVN Engineer elements on 3 Feb 67. Construction of connecting taxiways and parking apron continues.

8. (U) Signal Operations.

a. The 54th Signal Battalion (Corps) provided support for Operations THAYER, GATLING, FARRAGUT, BYRD, PERSHING, SUMMERALL, SAM HOUSTON, and FRANCIS MARION.

b. For the first time in the II Corps, tactical tropospheric scatter equipment (AN/TRC-129) was used in support of a combat operation. In support of Operation SUMMERALL, the MACV contingency package was used to establish a system from Khanh Duong to Dragon Mountain.

c. The 459th Signal Battalion, part of the 21st Signal Group, activated the Nha Trang Area Communications Center on 18 Feb 67, relieving the I FFORCEV Communications Center of area responsibility.

d. A program of VHF test systems in the II CTZ continues. During this period, systems were installed from Lang Bian Mountain to Nhon Co and from Dragon Mountain to Dak To.

9. (U) Information Office.

a. February 1967 saw the initial results of three months of labor on I FFORCEV's monthly magazine, "The Typhoon." The Assistant Information Officer made two trips to the printer in Okinawa, accompanied each time by an officer from the 5th Public Information Detachment. On 6 Feb 67 the first edition was distributed. The second edition was distributed on 19 Feb 67.

b. Two visits were made to Hq, I FFORCEV during February by information officers from higher headquarters. On 9 Feb 67 Col Meacham, the new USARV IO, made an initial visit to the headquarters accompanied by Col Greene, Deputy IO, MACV. On the 10th and 11th, LTC Williams, I FFORCEV IO, accompanied Colonels Meacham and Greene as they visited OPCON unit information officers in II Corps Tactical Zone. On 27 Feb 67,

69
CONFIDENTIAL

CONFIDENTIAL

74

AVFA-GC-OT

SUBJECT: Operational Report for Quarterly Period Ending 30 April 1967
RCS CSFOR-65 (U)

Col Meacham returned, this time with Col Bankson, MACV IO, to confer with the Commanding General, Chief of Staff and I FTORCEV Information Officer.

c. During February, March and April 1967, the Commanding General was interviewed by 17 noted correspondents. March was the busiest month on record for correspondent interviews.

d. Photo coverage was provided during the reporting period for numerous distinguished visitors.

e. The 5th Public Information Detachment continued to place major emphasis on preparing future editions of "The Typhoon" for publication. By the end of April 1967, the March and April edition had appeared in print, and the May edition had been delivered to the printer. In late April 1967 the detachment received a long-awaited general order reorganizing it into an FA & FB team. Equipment adjustment began in accordance with the new TO&E.

f. The 11th Public Information Detachment continued to billet and in other ways aid correspondents and visiting information personnel. Forty-nine were accommodated during February 1967. The 11th PID saw considerable expansion during March and April. In early March, a branch camp was established in Pleiku and in early April another branch camp at Qui Nhon. The Nha Trang Camp handled 194 correspondents and visiting information personnel during March and April, the Pleiku camp 142 during the period 8 March - 30 April and the Qui Nhon Camp 32 during the period 10 - 30 April.

g. The Information Office itself was affected by the expansion of 11th PID activities and the conversion of the 5th PID. On 10 April 1967 three men detailed for duty since September 1966 with the Information Office were recalled by the 11th PID in order to man the newly established Qui Nhon press camp. On 24 April 1967, after the Headquarters Commandant had vacated his office space on the north porch of the headquarters, where he had been co-located with the Information Officer, the 5th PID moved its personnel in to occupy the vacated area.

h. A major event of the period was the commencement of operations of the AFRTS television station on Hon Tre Island. In a five-minute television appearance on 13 March 1967, General Larsen officially opened the station.

i. Home town News Release activity centered around the cutting of sound recording tapes for use on Mother's Day back in the U.S., and the photographing of troops contributing to a local Vietnamese Boy Scout Fund Drive.

10. (U) Inspector General Activities:

a. There were seven complaints and forty-six requests for assistance, advice, or information received during the period. Five of the complaints were unjustified and two were justified. None of the complaints indicated any evidence of trends, widespread irregularities, or problems detrimental to the efficiency or reputation of this command.

b. The Inspector General participated in the command inspections of the following units on the dates indicated.

- | | |
|------------------------------|-------------|
| (1) 54th Sig Bn | - 17 Feb 67 |
| (2) 272d MP Co & 313th RR Bn | - 24 Feb 67 |

70

CONFIDENTIAL

CONFIDENTIAL

15

AVFA-GC-OT

SUBJECT: Operational Report for Quarterly Period Ending 30 April 1967
RCS CSFOR-65 (U)

- (3) Hq Co, I FFORCEV, 55th MI Det
5th PID, 11th PID, and 64th Engr Det - 3 March 1967
- (4) HNB, I FFORCEV Arty -17 March 1967
- (5) 297th Car Co and 41st CA Co -23 March 1967
- (6) 43d APU -23 March 1967

c. The Inspector General participated in an IG Orientation conference, conducted by TIG in Saigon, during the period 22 April 1967 thru 29 April 1967.

SECTION II (U) - COMMANDER'S OBSERVATIONS AND RECOMMENDATIONS:

Part I: Observations (Lessons Learned)

1. (C) Operations:

a. Item: Incidents involving death or injury of friendly military personnel or civilians.

Discussion: Incidents in which friendly military and civilian personnel are becoming casualties as a result of misdirected air and ground fires are recurring with disturbing frequency. Accuracy of all fire support elements in II CTZ is well known and respected. As a result of this respect, maneuver element commanders do not hesitate to call for fires in close proximity to friendly forces. The responsiveness, and destructive capability of our own firepower, coupled with the populated areas in which this war is being fought, provides a situation wherein delivery errors can be tragic.

Observations: Immediate attention should be given to the orientation of all personnel on the directives which establish procedures and responsibilities for command, control, and coordination of US military air and ground operations in RVN. Particular emphasis should be placed on practical map reading and land navigation training. Training should include the use of artillery and illumination for marking locations, and to determine position areas when prominent landmarks are not available. The best personnel available should be assigned to artillery FDC, FO and IO positions. Intensify FDC, FO and AO (aerial observer) training with emphasis on aerial observer training and adherence to established procedures which employ a sound system of checks to eliminate human error. In addition, attention to detail in fire direction center operations and adherence to standard operating procedures at the firing units will decrease the number of incidents.

b. Item: Effectiveness of Psy Op in exploiting intelligence and tactical situations.

Discussion: The effectiveness of psychological exploitation for intelligence and tactical situations is inadequate even though lucrative and timely information is available from the Hoi Chanh who surrenders to US/FWMAF tactical units. The majority of Hoi Chanh surrender to Vietnamese government authorities and are not readily available for timely exploitation.

Observations: The lack of Hoi Chanh exploitation in the past was attributed to GVN failure to provide guidance and encouragement

71

CONFIDENTIAL

CONFIDENTIAL

76

AVFA-GC-OT

SUBJECT: Operational Report for Quarterly Period Ending 30 April
1967, RCS CSFOR-67 (U)

techniques and procedures. CIDG elements have provided security for US FSB's.

Observations: Combined operations provide an opportunity for ARVN, USSF/CIDG and other indigenous forces to improve their effectiveness by training with US units. When indigenous personnel provide security for US FSB's, additional US maneuver elements are available to perform search and destroy operations. As a result of combined operations, ARVN, USSF/CIDG and other indigenous personnel improved their unit's ability to accomplish its tactical mission has been greatly enhanced.

2. (C) Intelligence

Item: 35mm Camera Capability

Discussion: The use of a 35mm camera with 200/500/1000mm lens employed during VR and FAC missions in an O-1 aircraft is an excellent immediate photographic capability available to ground commanders. This photography complements high performance aircraft coverage in those areas of interest or suspicion derived by interpretation of such photography and can be studied in detail through spot photographs taken with the 35mm camera and one of the large lens. Targets can be developed from these enlargements as they are not normally identifiable on small scale photography. Combat operations have actually been planned and conducted as a result of intelligence provided by these 35mm enlargements.

Observation: This Hq has requested that action be taken to provide this capability down to US battalion level and advisory sector level throughout II CTZ.

3. (C) Logistics:

a. Item: Periodic Logistics Report (PLR).

Discussion: During the quarter, the PLR was changed from a weekly to a bi-monthly report. The change was the result of separate request by this headquarters and 1st Logistical Command to USARV. Basis of the request was to allow sufficient time for support command to act on a PLR before the next report arrived.

Observations: The new reporting periods will provide more time for the 1st Log Cmd to respond to problem areas cited in the PLR.

b. Item: ARVN Barrier Material Supply.

Discussion: It has been reported that II and V ARVN Log Cmd have adequate barrier material supplies on hand. However, recent inspection reports indicates that a number of outposts in II CTZ are short of barrier materials. A check with the responsible personnel indicated that the current problem is a result of the reluctance of units to requisition required barrier materials.

Observations: Unit advisors must encourage their counterparts to request required barrier materials.

72
CONFIDENTIAL

CONFIDENTIAL

77
AVFA-GC-OT

SUBJECT: Operational Report for Quarterly Period Ending 30 April
1967, RCS CSFOR-65 (U)

to use them for that purpose. However, the Ministry of Information and Chieu Hoi published guidelines on the organization and administration of Chieu Hoi armed propaganda teams on 29 April 1967. Implementation of out-lined policies should contribute immeasurably to gathering of intelligence information.

c. Item: Employment of Dummy Positions.

Discussion: A battalion TAC CP and its security element were emplaced on a hilltop by helicopter. A defensive perimeter was established, and the first priority of tasks was assigned to digging-in and clearing fields of fire. The second priority was given to preparation of covered sleeping positions. Later that day several dummy positions were prepared 15-20 meters forward of the perimeter along likely avenues of approach. Empty C-rations cans and paper were deliberately scattered around these positions to give an appearance of being occupied, and to increase the probability of being detected at night. During the night an enemy patrol of unknown size probed the perimeter employing 15 hand grenades. All of the enemy grenades exploded in the vicinity of the dummy positions without causing friendly casualties. During daylight the next day the dummy positions were occupied and improved to continue the deception. The security force had been reluctant to throw grenades at night because of numerous trees and vines in the area. Grenade lanes were cleared and the security force practiced using rocks. When the perimeter was probed the following two nights, the security force had confidence to use grenades on suspected enemy locations.

Observation: The combination of deception and an aggressive defense succeeded in deceiving the enemy and prevented friendly casualties. Dummy positions forward of the perimeter will probably confuse and deceive the enemy at night. The positions should be occupied during the day and covered by fire during darkness. Grenade lanes must be cleared when dense vegetation restricts the use of hand grenades.

d. Item: Command Relationship Between US and USSF/CIDG Forces in Combined Operations.

Discussions: Combined operations which include US and USSF/CIDG units must have a clearly defined command relationship to preclude misunderstandings, and to provide the tactical commanders the opportunity to effect maximum coordination of effort in accomplishing the mission.

Observations: Appropriate instructions clarifying the command relationship in situations involving US commanders and USSF/CIDG units have been disseminated to all commanders concerned.

e. Item: Combined Operations.

Discussion: ARVN, USSF/CIDG units have been encouraged to participate in all US major operations in II Corps CTZ. Presently, ARVN, USSF/CIDG and/or other indigenous forces are employed with US units in combined operations throughout II Corps in a coordinated effort to seek out and destroy enemy forces. ARVN, USSF/CIDG and other indigenous units have been integrated with US units down to platoon level on occasions in order that they might obtain maximum benefit in employing tactical

CONFIDENTIAL

CONFIDENTIAL

78

AVFA-GC-OT

SUBJECT: Operational Report for Quarterly Period Ending 30 April 1967, RCS CSFOR-65 (U)

4. (C) Other:

a. Item: Expendable Supplies for Reproduction Services:

Discussion: After arrival in country, non-standard reproduction equipment was acquired in response to a requirement for a reproduction capability of greater capacity than was possible with the normally authorized equipment. After one and one-half years of effort, a smoothly operating system for the procurement and distribution of expendable supplies is about to be established. During the interim, continued operation of this equipment has been extremely difficult and on an almost constant emergency basis. The principle difficulty has been one of establishing a non-standard demand in a rapidly expanding combat supply channel.

Observation: Avoid the acquisition of non-standard reproduction equipment whenever possible until it has been determined that the supply system has sufficient stability to assure adequate support.

b. Item: Reproduction Messages:

Discussion: The rapid reproduction of messages is an item of paramount importance in support of this headquarters since much of this traffic consists of situation and intelligence reports. Presently this work load is being accomplished by the use of a 3M "Secretary" Thermofax Machine. Approximately 6000 sheets of Thermofax paper are run thru this machine each week to fill the requirements for copies that are needed by elements of this headquarters. This model machine does not satisfactorily fulfill the requirement placed on it. The following disadvantages have been noted.

(1) Parts and supplies, particularly belts, are practically nonexistent in Vietnam .

(2) It is a relatively slow and costly process.

(3) Copies are often barely legible.

(4) Copies deteriorate with age.

Observation: There is need for a clean, quick, and relatively inexpensive method of reproducing message traffic.

c. Item: Uniformity of PW Processing Requirements.

Discussions: When the II Corps Combat Captive (PW) Camp was quarantined because of meningitis, arrangements were made to transfer I FFORCEV and KOK captured prisoners to other Corps PW Camps. During these moves, it was discovered that administrative requirements differed from camp to camp, i.e. in the Corps preliminary interrogation reports were required to accompany the prisoner; in another, rosters in advance of shipment were requested; in a third case, extra copies of the Detainee Report (USARV Form 564) were required. These differences in processing procedures created unnecessary delays and confusion in addition to placing an extra administrative burden on the combat units. The need for a standard operating procedure applicable throughout Vietnam was obvious.

74

CONFIDENTIAL

CONFIDENTIAL

79

AVFA-GC-OT

SUBJECT: Operational Report for Quarterly Period Ending 30 April 1967
RCS CSFOR-65 (U)

Observation: The adoption of a standard policy applicable throughout Vietnam is required to eliminate variations in processing and administrative requirements involved in PW evacuation procedures.

d. Item: Employment of PW.

Discussion: Utilization of prisoners of war labor is of growing concern in the II CTZ. At the present time less than 10% of the prisoners in the PW camps are productively employed with the balance doing nothing but meeting required formations. This lack of activity presents a potentially explosive situation. With schools, hospitals, and public work projects to be accomplished, prisoner labor should be utilized to the maximum extent possible. Increased efforts must be made by US Advisory personnel to convince ARVN military authorities that useful work projects are a necessity to prevent disorder, to take advantage of the available labor source and to produce a trained labor force for RVN upon cessation of hostilities. Initiative and ingenuity play a large role in acquiring suitable work projects for this valuable source of labor. With the PW capture rate increasing, the problem becomes more acute.

Observation: Increased utilization of PW labor resources must be accomplished as a GVN National Policy. US Advisory personnel must impress their Vietnamese counterparts with the advantages, potential, and the necessity of utilizing the PW labor force within the provisions of the Geneva convention. Proper utilization will contribute to smooth camp operations, relieve discontentment, and assist in vocational training of those PW released in RVN at the conclusion of hostilities.

e. Item: Psychological Exploitation of Prisoners of War.

Discussion:

(1) Psychological exploitation of PWs can be used for propaganda against the enemy, i.e., random sampling of data gathered from NVA PW in II Corps PW camp indicated that 6% of the NVA PW were farmers, while two tenths of one percent were fishermen; 33% of the prisoners sampled professed the Catholic faith. The low percentage of fishermen may indicate that recruiting is primarily from the inland provinces or that fishermen are exempt from military service. The higher than expected percentage of prisoners claiming the Catholic religion (Catholic population in North Vietnam is about 300,000) indicates either discrimination in the draft, or that religion is claimed but not in fact practiced. These statistics if valid could be used for propaganda directed at farmers or members of the Catholic religion in North Vietnam by pointing out the inequity of the situation and against other groups to point out possible discriminatory practices by the government of North Vietnam. Information as to home and family locations, education, family background, age, marital status, and civilian occupation may all be useful for propaganda purposes. NVA and VC should be treated as separate categories to determine the type propaganda most suitable for each group. Prisoners background should be examined in depth to determine availability of propaganda producing information.

(2) At the cessation of hostilities, many PWs will be released in South Vietnam with the same attitude and beliefs they had at the time of capture unless steps are taken to indoctrinate them in GVN policies, concepts and belief in the democratic way. Psywar teams should have the capability of conducting training programs on a continuing basis through the use of lectures, films, and daily personal contact. A thoroughly developed program would not only change prisoner attitude, but also make useful citizens of those who wish to remain in South Vietnam when they are repatriated or released.

75

CONFIDENTIAL

CONFIDENTIAL

80

AVFA-GC-OT

SUBJECT: Operational Report for Quarterly Period Ending 30 April 1967
RCS CSFOR-65 (U)

(3) Psywar teams are authorized in the TOE of the PW camps. Although personnel are assigned against these authorizations, they are untrained and inadequate in numbers to properly carry out the task of re-education. The philosophy that on-the-job training will produce a qualified psychological operator lacks realism and full appreciation of the problem. While weekly classes are conducted at the Pleiku PW camp, they do not involve all prisoners nor is the depth of the instruction sufficient to reach the PW through establishment of psychological rapport.

Observation: Prisoners of war interviewed at the PW camps represent a valuable source of information which could be developed for psychological warfare. Additionally, as most of the PW will eventually be returned to full citizenship in South Vietnam, a program of re-education to indoctrinate this group in GVN philosophy should be undertaken.

PART II: RECOMMENDATIONS:

(C) Logistics: Reference para 3b, Part I, Section II. Unit advisors should encourage their ARVN counterparts to request required barrier materials and follow through on requisitions.

FOR THE COMMANDER:

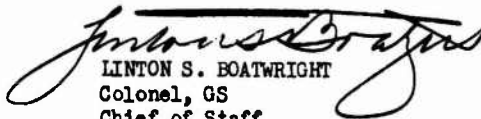
LINTON S. BOATWRIGHT
Colonel, GS
Chief of Staff

22 Incl
as
Incl withdrawn, Hqs, DA
#2-7, 12-15, 19, 21-22

DISTRIBUTION:

2-CINCPAC
6-USARV
1-CG II FFORCEV
1-CG 1st Cav Div
1-CG 4th Inf Div
1-CG 1st Bde, 101st Abn Div
1-CG I FFORCEV Arty
1-CG 3d Bde, 25th Inf Div
1-DSA, II Corps
1-ACofS, G1
1-ACofS, G2
3-ACofS, G3
1-ACofS, G4
1-US Army War College ATTN: Library Q-2149
1-Comdt, USA C&GSC, Ft Leavenworth
2-13th Mil Hist Det

76

CONFIDENTIAL

SECRET

81

AVHGC-DST (30 May 67) 1st Ind
SUBJECT: Operational Report-Lessons Learned for the Period Ending
30 April 1967 (RCS CSFOR-65) (U)

HEADQUARTERS, UNITED STATES ARMY VIETNAM, APO San Francisco 96307 10 JUL 1967

TO: Commander in Chief, United States Army, Pacific, ATTN: GPOP-OT,
APO 96558

Assistant Chief of Staff for Force Development, Department of the
Army, Washington, D.C. 20310

1. (U) This headquarters has reviewed the Operational Report-
Lessons Learned for the period ending 30 April 1967 from Headquarters,
I Field Force Vietnam.

2. (S) Pertinent comments follow:

a. Reference item concerning the lack of photo copier, para-
graph 2b(2), page 1: I Field Force, Vietnam AG office has been informed
of the procedures to be followed to obtain a photo copier.

b. Reference item concerning the evacuation of rice from un-
accessible areas, paragraph 3f(7)(d), page 37: Procuring GVN assets to
secure and evacuate captured rice is often impossible and the use of US
tactical transportation and manpower is seldom operationally feasible.
However, the extent to which the local tactical commander will utilize
his resources to evacuate rice from difficult and inaccessible areas de-
pends on the tactical situation at the time. This problem is under
constant study at all command levels and additional guidance on evacuation
of captured rice was promulgated by both Hq USARV and Hq USMACV during
the quarterly period ending 30 April 1967.

c. Reference item concerning the herbicide program in II CTZ,
paragraph 3h(6)(a), page 47: The proposed "Omnibus Plan" should reduce
the response time to attack a herbicide target by a considerable factor.
MACV has been made aware of this problem.

d. Reference item concerning supply items in short supply,
paragraph 4b(1), page 49: The supply status of items listed in para-
graph 4b(1) continues to improve, particularly air delivery equipment,
AN/PRC-25 radios, 2½ ton trucks and standard generators.

e. Reference item concerning personnel management, paragraph
5b(1), page 52: This headquarters is instituting procedures to provide
each major commander with machine prepared listings of assignment in-
structions for individuals assigned his command. This method is faster

Downgraded at 8 year intervals
Declassified after 12 years
DOD DIR 5200.10

G1-67-1899 77

G4-S-67-1587
SECRET

G3-S-67-1780

HQ USARPAC 4/162
S-67- By 1 of 3 Cys
Pg. of Pgs

ARV67S-1943

0711599

SECRET

82

AVHGC-DST (30 May 67) 1st Ind
SUBJECT: Operational Report-Lessons Learned for the Period Ending
30 April 1967 (RCS CSFOR-65) (U)

and more effective that the previous procedure using manually prepared rosters which contained assignment instructions for individuals in all commands. Procedures are also being implemented to provide each command with a listing of those individuals for whom assignment instructions have not been received. These listings will provide for closer control of those personnel, and identify individuals on whom special attention should be focused by DA, this headquarters, and the major commander. Further improvement of the assignment procedures can be made by Department of the Army, Office of Personnel Operations providing more timely notification to this headquarters of individuals' assignments.

f. Reference item concerning the use of marijuana, paragraph 4f(1)(b), page 54: Although not a serious problem, the use of marijuana by a relatively small number of US forces personnel is difficult to eliminate. Progress is being made and current emphasis on preventative and enforcement measures is considered adequate and appropriate.

g. Reference item concerning the high rate of traffic accidents, paragraph 4f(1)(c)2, page 55: Concur. Usable roadways in Vietnam are inadequate for the number of motor vehicles, bicycles and pedestrians who utilize them each day. Until this problem is eliminated by construction of additional and improved highway capacities, the accident rate will continue to be high despite stringent education and enforcement programs. USARV Regulation 190-3, published on 7 May 1967, establishes traffic rules and regulations and traffic accident investigation procedures for all US Army vehicles and personnel in this command. Additional emphasis is implemented by dispatch of command letters to appropriate commanders requiring necessary investigative and corrective actions in each case involving a traffic fatality in which a US Army vehicle or operator was at fault.

h. Reference item concerning camera capability, page 72: Procedures for obtaining equipment in excess of authorized allowances are contained in USARV message (U) AVHGC-OT, DTG 251132Z Mar 67, subject: Changes in Equipment Authorizations.

i. Reference item concerning expendable supplies for reproduction services, page 74: Concur in observation. The observation is one which has command interest from the Department of Defense down to the company commander level. The supply system, in order to properly research, analyze and test equipment for cataloging and standardization purposes, must have sufficient time to accomplish all of these related tasks. Quite often a requirement is generated in the field and an immediate delivery requested. One such program initiated in RVN is the DA

78

SECRET

SECRET

AVHGC-DST (30 May 67)

1st Ind

SUBJECT: Operational Report-Lessons Learned for the Period Ending
30 April 1967 (RCS CSFOR-65) (U)

procedures for ENSURE. Once an item has been type classified and approved another item of greater potential, often less expensive, has been developed and commanders are interested in seeing the item adopted by the military. When a decision has been made to obtain a non-standard item action is taken to provide repair parts or service contracts. The necessary expendable items are assigned FSN's to enable unit supply personnel to procure them at self-service supply centers or supply points. No further action than that already underway by USAMC and DA to avoid acquisition of non-standard reproduction equipment is contemplated.

j. Reference item concerning reproduction messages, page 74: Concur with observation; non-concur with discussion. The same equipment used by this headquarters is available to the FFORCEV headquarters. The TOE spirit process reproducing machine, model E-20, FSN 3610-813-1284 will satisfy the requirements listed, and stockage of expendable supplies is adequate. Other machines available are the Multilith 1250 and the 3M-209 Copier. Action will be taken by this headquarters to obtain information relative to operational problem in connection with expendable supply for reproduction services.

k. Reference item concerning a shortage of linguists, paragraph 2b(2), page 1: Concur. The shortage of linguists within this command is fully realized by all headquarters concerned with this problem. IFFV has an established requirement of 46 Vietnamese linguists all of which were on requisition until recent cancellation action by DA. Six validated linguist requirements remain for IFFV through October 1967. Two fluent linguists are scheduled to arrive during the months June through October for assignment to IFFV. In addition, USARV is programmed to receive 400 linguists from the 12 week Vietnamese course at the Defense Language Institute, Fort Bliss, Texas. First input of these sub-fluent linguists is not expected to arrive in this command until October 1967. As prescribed by DA, these personnel must be temporarily utilized in O4B positions until CONUS school output can furnish sufficient O4B's to meet USARV requirements.

FOR THE COMMANDER:

22 Incl
nc**SECRET**

CONFIDENTIAL

RD
84

GPOP-DT(30 May 67) 2d Ind (C)
SUBJECT: Operational Report-Lessons Learned for the Period Ending
30 April 1967 (RCS GSFOR-65), HQ I Fld Force Vietnam

HQ, US ARMY, PACIFIC, APO San Francisco 96558 9 AUG 1967

TO: Assistant Chief of Staff for Force Development, Department of the
Army, Washington, D. C. 20310

(C) This headquarters has reviewed subject report and concurs in the
report as indorsed subject to the following comments pertaining to
Section I, paragraph 5a(2):

a. No shortage in MOS 31M was indicated in the 5th Signal
Battalion for either 30 April or 31 May, according to DPU data.

	54th Sig Bn		USARV	
	<u>Auth</u>	<u>Asgd</u>	<u>Auth</u>	<u>Asgd</u>
30 Apr	43	86	881	1,023
31 May	43	83	881	959

b. Personnel assigned, however, were generally in lower
grades than those authorized.

FOR THE COMMANDER IN CHIEF:

G. L. McMullin
G. L. McMULLIN
MAJ, AGC
Asst AG

22 Incl
nc

Downgraded at 3 year intervals
Declassified after 12 years
DOD DIR 5200.10

80

RBI
2711599

CONFIDENTIAL

HQ USARPAC
S-87- 4162
REGRADED CONFIDENTIAL
WHEN SEPARATED FROM
SECRET COMPONENTS

CONFIDENTIAL

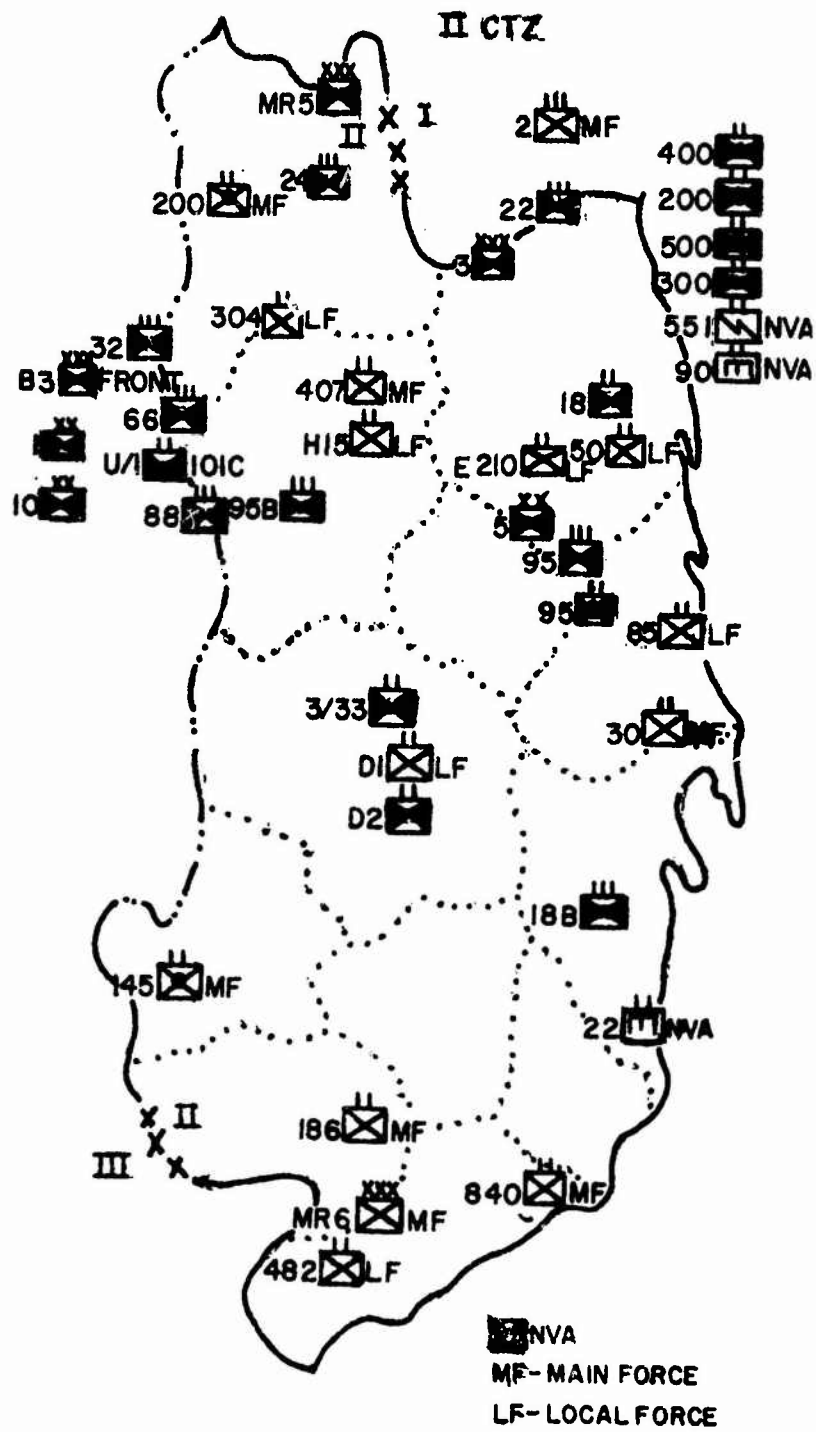

CONFIDENTIAL

CONFIDENTIAL

HEADQUARTERS I FFORCEV TASK ORGANIZATION

AS OF 30 APRIL 1967

ASSIGNED UNITS	AUTHORITY	STATUS	AUTHORITY	LOC
Hq Co, I FFORCEV	USARV GO 56, 11 Mar 66	Attached Hq I FFORCEV Arty	I FFORCEV GO 391, 9 May 67	NHA
Hq & Hq Btry I FFORCEV Arty	USARV GO 56, 11 Mar 66	Attached Hq I FFORCEV Arty	I FFORCEV GO 391, 9 May 67	NHA
41st Arty Group	USARV GO 2077, 6 May 67 (eff 29 Apr 67)	Attached Hq I FFORCEV Arty	I FFORCEV GO 391, 9 May 67	PHC
52d Arty Group	USARV GO 57, 5 Jan 67	Attached Hq I FFORCEV Arty	I FFORCEV GO 391, 9 May 67	PKU
3d Bn (105)(SP) 6th Arty	USARV GO 57, 5 Jan 67	Attached 52d Arty Gp	I FFORCEV GO 287, 29 Jul 66	PKU
7th Bn (105)(T) 13th Arty	USARV GO 6208, 31 Oct 66	Attached 41st Arty Gp	I FFORCEV GO 391, 9 May 67	PHC
w/A Btry 3d Bn 18th Arty (8") (SP) Atchd				
6th Bn (175)(SP) 14th Arty	USARV GO 1205, 26 Oct 65	Attached 52d Arty Gp	I FFORCEV GO 287, 29 Jul 66	PKU
21 Bn (105)(T) 17th Arty	USARV GO 57, 5 Jan 67	Attached 1st Cav Div (AM)	I FFORCEV GO 16, 25 Oct 65	AKE
HNB, 8th Bn, 26 Arty (TA)	USARV GO 361, 25 Jan 67	Attached 41st Arty Gp	I FFORCEV GO 391, 9 May 67	QNH
5th Bn (105)(T) 27 Arty	USARV GO 1762, 30 Nov 65	Attached Hq I FFORCEV Arty	I FFORCEV GO 490, 19 Nov 66	TYH
Btry B, 29th Arty (SCHLT)	USARV GO 1205, 27 Oct 65	Attached 41st Arty Gp	I FFORCEV GO 391, 9 May 67	QNH
Btry G, 29th Arty (SCHLT)	USARV GO 1417, 29 Mar 67	*Attached Hq I FFORCEV Arty	I FFORCEV GO 334, 11 Apr 67	DNG
1st Bn (155)(T) 30th Arty	USARV GO 1868, 12 Dec 65	Attached 41st Arty Gp	I FFORCEV GO 391, 9 May 67	QNH
w/Btry C 6th Bn 16th Arty Atchd				
6th Bn (8") (SP) 32d Arty	USARV GO 1417, 29 Mar 67	Attached Hq I FFORCEV Arty	I FFORCEV GO 334, 11 Apr 67	TYH
1st Bn (105)(SP) 40th Arty	USARV GO 6524, 27 Nov 66	*Attached Hq I FFORCEV Arty	I FFORCEV GO 532, 5 Dec 66	DHA
1st Bn (AW)(SP) 44th Arty	USARV GO 6524, 27 Nov 66	*Attached Hq I FFORCEV Arty	I FFORCEV GO 532, 5 Dec 66	DHA
w/Btry G (MG) 65th AD atchd				
4th Bn (AW)(SP) 60th Arty	USARV GO 1195, 18 Mar 67	Attached 41st Arty Gp	I FFORCEV GO 391, 9 May 67	QNH
w/Btry E, (MG) 41st AD atchd				
1st Bn (155)(T) 92d Arty	USARV GO 1195, 18 Mar 67	Attached 52d Arty Gp	I FFORCEV GO 334, 11 Apr 67	PKU
1st Bn (175)(SP) 94th Arty	USARV GO 6525, 27 Nov 66	*Attached Hq I FFORCEV Arty	I FFORCEV GO 532, 5 Dec 66	DHA
w/Btry B 6th Bn (8") (SP) 27th Arty atchd				
235th FA Det (Radar)	USARV GO 1913, 28 Mar 66	Attached 52d Arty Gp	I FFORCEV GO 287, 29 Jul 66	PKU
237th FA Det (Radar)	USARV GO 1913, 28 Mar 67	Attached 52d Arty Gp	I FFORCEV GO 612, 31 Dec 66	DHA

NOTE: *Atchd to III M.F for OPCON, admin. and logistical spt, less JETV peculiar admin and logistical spt. Obtain Army peculiar logistical spt from 1st Log Comd.

CONFIDENTIAL

82

CONFIDENTIAL

Assigned Units (cont)

238th FA Det (Radar)	USARV GO 1913, 28 Mar 65	Attached 17th Avn Gp	I FFORCEV GO 136, 15 Apr 66	DBT
77th FA Det (Radar)	USARV GO 1913, 28 Mar 66	Attached 52d Arty Gp	I FFORCEV GO 287, 29 Jul 66	QNH
68th In Det (R.D.R)	USARV GO 1913, 28 Mar 66	Attached 52d Avn Bn	I FFORCEV GO 415, 25 Oct 66	PKU
54th Inf Det (Grd Svln.)	USARV GO 3137, 27 May 66	Attached 1st Cav Div (AM)	I FFORCEV GO 200, 9 Jun 66	AKE
54th Sig Bn (Corps)	USARV GO 668, 20 Sep 65			NHA
272d MP Co	USARV GO 668, 20 Sep 65			NHA
64th Engr Det (Terrain)	USARV GO 159, 13 Jan 66			NHA
55th MI Det	USARV GO 1229, 27 Oct 65			NHA
209th Sig Det (KA)	USARV GO 1590, 15 Nov 65	Attached to 54th Sig Bn	I FFORCEV GO 25, 16 Nov 65	NHA
297th TC Co (War)	USARV GO 5953, 6 Oct 66			NHA
43d AFU (APO 96350)	USARV GO 5953, 6 Oct 66			NHA

ATTACHED UNITS

AUTHORITY

STATUS

AUTHORITY

LOC

194th Chem Plat	USARV GO 1056, 16 Oct 65	Attached 1st Cav Div (AM)	I FFORCEV GO 16, 25 Oct 65	AKE
26th Chem Det (GER CTR)	USARV GO 1056, 16 Oct 65	Attached 1st Cav Div (AM)	I FFORCEV GO 16, 25 Oct 65	AKE
191st MI Det	USARV GO 1056, 16 Oct 65	Attached 1st Cav Div (AM)	I FFORCEV GO 16, 25 Oct 65	AKE
13th MIL Hist Det	USARV GO 2161, 28 Dec 65			NHA
41st CA Co (-)	USARV GO 4079, 22 Jun 66			NHA
11th PI Det	USARV GO 4878, 21 Jul 66			NHA
5th PI Det	USARV GO 5587, 8 Sep 66			NHA
313 RR BN	509th RR Gp GO 78, 29 Jul 66			NHA
330 RR Co	509th RR Gp GO 78, 29 Jul 66			PKU

CONFIDENTIAL

CONFIDENTIAL

HEADQUARTERS I FFORCEV TASK ORGANIZATION

<u>OPCON UNITS</u>	<u>AUTHORITY</u>	<u>STATUS</u>	<u>AUTHORITY</u>	<u>LOC</u>
1st Cav Div Div (M) 4th Inf Div (-)	MACV LOI 1-66, 29 Mar 66 USJRV OPLAN (OP ROBIN) 78-66 10 Jul 66		I FFORCEV GO 450, 31 Oct 66	AKE
II Corps Adv Cp 245th PsyOp Co	MACV LOI 1-66, 29 Mar 66 MACV ltr subj: Employment of US Army 6th PsyOp Bn, 30 May 66			PKU NHA
17th Avn Co HHC Det B-50, 5th SFG (Project OMMIA)	MACV LOI 1-66, 29 Mar 66 OPOON assumed by CG, I FFORCEV on 1 Oct 66, by I FFORCEV GO 396, 13 Oct 66			NHA NHA
Co B, 5th SFG (ABN)	MACV LOI 1-66, 29 Mar 66		I FFORCEV msg (S) A-2035, 150957Z Dec 66	PKU

CONFIDENTIAL

88

CONFIDENTIAL

MACV LTR MACOC 4, HQ USARV
20 JUL 66, SUBJ: ARMY AVN ALLOCATIONS (U)
PLACES THE FOLLOWING ALLOCATIONS CURRENTLY
UNDER CONTROL OF THE 17TH AVN GP IN SUPPORT
OF HQ I FFOICEV

- | | |
|------------------------|----------------------------------|
| <u>52d Avn Bn HHD</u> | <u>14th Avn Bn HHD</u> |
| 1196h Avn Co (AML) | 161st Avn Bn ^{Co} (AML) |
| 155th Avn Co (AML) | 174th Avn Bn ^{Co} (AML) |
| 170th Avn Co (AML) | 176th Avn Bn ^{Co} (AML) |
| 179th Avn Co (AML) | 196th Avn Co (MEDHEL) |
| <u>10th Avn Bn HHD</u> | <u>223d Avn Bn HHD</u> |
| 48th Avn Co (AML) | 18th Avn Co (OTTER) |
| 117th Avn Co (AML) | 183d Avn Co (OBSN LT) |
| 129th Avn Co (AML) | 219th Avn Co (RAC) |
| 180th Avn Co (MEDHEL) | |

CONFIDENTIAL

CONFIDENTIAL

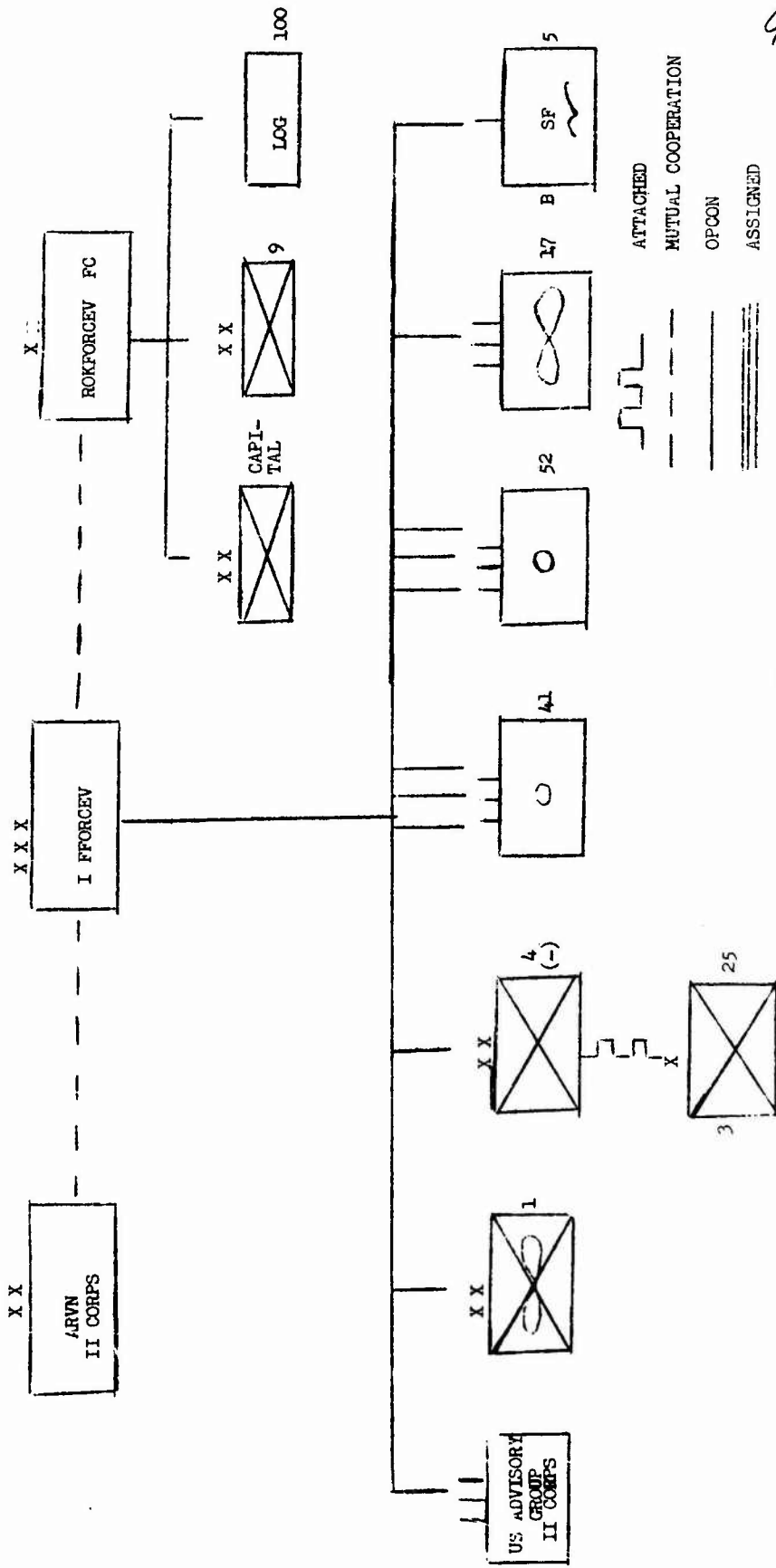

CONFIDENTIAL

sheet 9

91
HEADQUARTERS
I FIELD FORCE VIETNAM
APO US Forces 96350

AVFA-GC-OT

12 March 1967

SUBJECT: Letter of Instructions

TO: US Observers for Operation Oh Jac Kyo

1. Situation: Since their arrival in Vietnam the ROK forces in II CTZ have enjoyed outstanding success in all operations. Their kill ratio, number of weapons captured, and their ability to rid populated areas of the VC infrastructure is noteworthy. In view of the above, we have been looking for an appropriate time to send observers with the ROK's so that a first hand view of tactics and techniques employed may be obtained. Operation Oh Jac Kyo in Phu Yen Province presents such an opportunity. You have been selected to observe the operation.

2. Mission: To observe ROK Combat Operations at the rifle company level during the period 16 - 30 March; to gather data for publication of lessons learned, new concepts and techniques; to report on your observation.

3. Execution: The functions and responsibilities of observers for Operation Oh Jac Kyo are as follows:

a. On arrival at the ROK rifle company designated by the Senior I FFORCEV Liaison officer with the ROK division, you will live, eat, and sleep with the company, and fight in defense of the company, if necessary. However, the primary purpose in being with the company is to observe. Comply with ROK SOP's on camouflage, light, and noise discipline. If possible, observe each type activity conducted by the company, i.e., search and destroy, cordon and search, ambush, psyops, and night operations.

b. Based on your observation, provide answers to the items listed below. Cite examples where possible.

(1) Maneuver tactics of small units:

- (a) How did the unit maintain security when on the move?
- (b) Comment on the effectiveness of ROK firepower during a meeting engagement.
- (c) Comment on noise discipline during operations.

FILE 10 3 PAGES

12 March 1967

92

(d) Comment on the avenues of approach normally used, i.e., ridge lines, cross compartment, etc.

(e) During the period of your observation, how far did platoons operate from each other?

(f) What size area does a company generally cover when searching? Comment on effectiveness of search operations.

(g) When searching, how far does the point squad lead the platoon? Platoon lead the company?

(h) What method of control is used at company level? Platoon?

(i) How are artillery forward observers used? How close to friendly troops is artillery employed?

(2) How do small units select terrain for blocking positions to fully utilize economy of force?

(3) How do ROK's get maximum secrecy and surprise in setting up ambushes?

(4) How much do the ROK's use close-in artillery fires in making kills?

(5) What size unit is optimum in search and destroy operations?

(6) In your opinion and from your observation, what appear to be the major contributing factors to the ROK success in getting a consistently high kill ratio?

(7) Describe in detail a village cordon and search operation.

(8) Comment on care and maintenance of weapons and equipment in the company.

(9) How are reconnaissance elements employed?

(10) How are prisoners, detainees and captured documents screened and processed?

(11) Are local people used to obtain information? How is this conducted?

93

AVFA-GC-OT
SUBJECT: Letter of Instructions

12 March 1967

c. The items above are the minimum on which comments are desired. Report other information which would be of use to this headquarters in publication of lessons learned.

4. Administration and Logistics: The Senior I FFORCEV Liaison officer with each ROK division will provide transportation and logistical support to the observers as required.

5. Command: Observers with the CRID and 9th ROK Inf Div will be under operational control of the respective Senior I FFORCEV Liaison officer with those divisions.

FOR THE COMMANDER:

LINTON S. BOATWRIGHT
Colonel, GS
Chief of Staff

OFFICIAL:

[Signature]
MARKS
G3

FOR OFFICIAL USE ONLY

HEADQUARTERS
I FIELD FORCE VIETNAM
APO 96350

AFSA-OC-OT

3 May 1967

SUBJECT: Tactics and Techniques used by Republic of Korea Forces in Vietnam

TO: SEE DISTRIBUTION

1. Introduction: Republic of Korea Army and Marine forces have enjoyed noteworthy success in battle in Vietnam. This fact is attested to by the numerous casualties they have inflicted on the enemy, the weapons they have captured, and their disruption of the Viet Cong infrastructure. In order to identify the tactics and techniques which were being employed by the ROKs to achieve these results, arrangements were made for temporary attachment of 32 US Army personnel to ROK units participating in Operation OH JAC KYO. Each observer team was comprised of one officer (Captain or 1st Lieutenant) and one non-commissioned officer (E-6 or higher). The observer teams were located with committed ROK rifle companies during the period 16 - 30 March 1967. The salient lessons learned contained herein have been selected from reports submitted by the US observers.

2. Tactics and Techniques.

a. Item: Officers take care of their men.

Discussion: Prior to the initial assault each officer and each enlisted man in the unit was inspected by the company commander. This was followed by a comprehensive briefing on the operation, safety precautions, sanitation, use of water purification tablets, and rules of engagement. At least twice a day, and always after a significant action, each platoon leader had a session with every one who had "dropped the ball" or had done a marginal job. This is a very formal affair - much like an after action critique. Company commanders and platoon leaders insured that their troops were fully conversant with each day's operational plan. ROK commanders took every opportunity to spell their men and to alternate jobs so that maximum possible rest was afforded every soldier. To this end, frequent breaks were routine when the tactical situation permitted. When the situation did not permit the frequent breaks, the troops seemed tireless.

Observation: There is outstanding rapport between officers, NCO's and their men. The officers take care of their men; the men take care of their officers.

b. Item: Discipline.

Discussion: Observer comments on the morale and discipline of the average soldier ranged from excellent to outstanding. Discipline appeared

FOR OFFICIAL USE ONLY

April 11 5:44 PM

WPA-GC-OT

SUBJECT: Lessons Learned (cont)

to be second nature for the ROK soldier: he obeyed orders quickly and cheerfully, he did not complain and appeared to apply his combat training without instructions of urging. In the absence of orders, he reacted automatically as he had been taught.

tion: Immediate reaction by the individual soldier when given an order, and in the absence of orders to react immediately as he has been trained, will enhance the efficiency of any unit.

c. Item: Morale

Discussion: Observers reported that a feeling of solidarity and mutual support existed among all ROK units. This was evident when support troops lined up and cheered the combat troops as they departed for combat operations. The eagerness of officers and men alike was evident at all times. The cheerful obedience to orders, desire to do a good job, and an aggressive attitude at the individual soldier level were indicative of exceptionally high morale.

Observation: Commanders should be aware of the many indicators of high morale and should be cognizant of the various approaches to achieving and maintaining a state of high morale in the unit.

d. Item: Tactics

Discussion: ROK units, without exception, employed tactics in line with established US Army doctrine. Squad, company, and battalion operations were characterized by skillful use of fire and maneuver and by strict fire discipline. A basic rule, which seemed to be followed in all observed instances, involved one element covering another whenever a tactical movement was underway. During Search and destroy operations companies moved out to their assigned areas with platoons separated by 150 to 200 meters, depending on the type of terrain encountered. One platoon usually remained behind as security for the headquarters element and also acted as the company reaction force in event of contact. Detailed search and destroy efforts by companies were accomplished by employing organic elements as follows in the 69 instances reported:

Platoons	- 46
1/2 Platoons	- 6
Squads	- 17

During movement to contact, company size units were employed in the majority of cases observed. The most commonly used tactic was to move with three rifle platoons on line at 150 - 200 meter intervals, so that reinforcement at point of initial contact could be quickly accomplished. The center platoon was followed by the company headquarters and it in turn by the rear guard platoon, which would be trailed by one of its squads acting as rear security. Within the platoon a V-formation or inverted wedge was usually employed. This formation lent itself to encircling the enemy or a village. The lead squads would envelop right and left

FOR OFFICIAL USE ONLY

FOR OFFICIAL USE ONLY

97 AFSA-GC-OT

SUBJECT: Lessons Learned (cont)

and the remainder of the platoon would search or attack as the situation required. It should be noted that regardless of the type operation or formation used, the actions were characterized by patience, a thorough estimate of the situation, use of fire and maneuver, and search and counter-search of suspected areas. The ROKs were very thorough and precise about searching. They took their time and moved only when the unit was ready. They prepared good plans, everyone knew the plan, and each element was mutually supporting. It was not unusual for the same area to be searched three or four times and by different platoons. Areas of operation for platoons and companies were usually smaller than those assigned US units. The unit remained in each objective area until the commander was satisfied that the area had been thoroughly combed. This persistence paid off time and again in rooting out the VC and finding his weapons and equipment.

Observation: Commanders at all levels must be made aware of the necessity to adhere to basic principles of infantry combat, regardless of the degree of sophistication in weapons and equipment. Patience and thoroughness in estimating the situation need to be stressed.

e. Item: Village cordon and search, and civilian interrogation techniques.

Discussion: According to 21 US observers who participated in cordon and search operations, the operations were characterized by careful planning, rapid execution, extreme thoroughness, and outstandingly effective exploitation of detainees and captured personnel. Movement to pre-selected positions around the hamlet was accomplished during the hours of darkness. With first light, the platoons followed the plan of operation to the letter. This sometimes involved one or two platoons remaining in blocking positions to the rear of the built up area, or a converging attack by all company elements. Civilians were collected and moved to a safe central location where they were guarded and exploited for information of immediate tactical value. Civilians were segregated according to age and sex, i.e., men, women, children. Women and children were usually interrogated in two separate groups. Men were questioned individually. The ROKs used rewards routinely to elicit information. They fed and provided medical attention to those people from whom they sought information. They also employed bribes of food, money, candy, and cigarettes to soften the more likely subjects such as women and children. Meanwhile, the hamlet was being searched and researched systematically. Every structure was entered by search teams, secured by other troops who remained at the ready outside. Special care was taken to search straw piles, wells, attics, storerooms, and air raid bunkers. Each trail was examined again, hedge rows were swept anew, and each hut and structure was re-entered. All of the above actions were executed automatically without command, noise, or confusion. Detainees were a valuable source of information. They were retained in one central area until the ROKs were convinced that they had been properly exploited. There was no rush to release the civilian populace to return to their homes, the theory being that if held long enough they will provide the desired information. The villagers themselves were used to point out VC dwellings and the location of weapons, booby traps, and enemy equipment.

Observation: Detainees and the civilian populace can be a valuable source of information. In absence of interrogators at the company level,

FOR OFFICIAL USE ONLY

AFR-GC-OT

SUBJECT: Lessons Learned (cont)

printed questionnaires can be used to gather routine information. Patience and thoroughness in village and hamlet searches will increase the chances of success. While surrounding the village or hamlet during hours of darkness appears to be the best method; units should vary the pattern of action.

f. Item: Ambushes.

Discussion: The usual ambush force was a squad, reinforced with one or more machine guns. An on-line formation was used with the automatic weapon (s) on the flank (s), about 20 meters off the selected trail. The position was thoroughly reconnoitered prior to dark and was occupied at last light or in darkness. All unnecessary equipment, to include poncho, was left at the company base. Faces were blackened and all equipment carried was taped or tied down. Ambush sites were not altered by cutting fields of fire or by digging in. Absolute light and noise discipline was maintained. Until contact was made, communications between squad members was accomplished through tugs on a length of rope or commo wire, strung between positions. No firing was permitted until the enemy was well within the killing zone. Troops in the ambush force remained quiet and awake throughout the period they were in the ambush, be it all day or all night. All individuals appeared to remain awake and alert with no help from the squad leader.

Observation: After observing the ROK ambushes, US observers were of the opinion that most US ambush forces are too large. The ambush position should be observed during daylight hours by the troops who will set up the ambush. This can be accomplished by a sweep or recon through the area prior to darkness, returning to the site after dark.

3. Summary: Factors which have contributed to the success of ROK forces include:

- a. The discipline, aggressiveness, training, patience and physical fitness of the ROK soldiers.
- b. Outstanding leadership.
- c. Adherence to tactical doctrine as is taught at US service schools and as is written in US manuals.
- d. Thorough planning.
- e. Careful initial reconnaissance.
- f. The time taken to develop the tactical situation.
- g. The sealing and blocking of selected area prior to entrance.
- h. Thoroughness of the search of selected areas.
- i. Use of the interpreters at company level. The interpreters were trained in division schools.

99

FOR OFFICIAL USE ONLY

AVFA-GC-OT

SUBJECT: Lessons Learned (cont)

4. The factors outlined above are not to suggest that the ROKs were outstanding in every respect because there were deficiencies noted. Nevertheless, they demonstrated that their grasp and practice of tactical fundamentals, their discipline, their patience, their persistence in attaining an objective, and their physical fitness were laudatory.

FOR THE COMMANDER:

William H. James
WILLIAM H. JAMES
Colonel, AGO
Adjutant General

DISTRIBUTION:

CG, 1st Cav (AM) - 50
CG, 4th Inf Div - 50
CG, 1st Bde, 101st - 25
Abn Div
1 ea Staff Section
2 ea Assigned unit
2 ea Attached unit

FOR OFFICIAL USE ONLY

701

HQ I FORCEV KEY PERSONNEL
and
FVMAF SENIOR COMMANDERS ON DATES INDICATED

<u>TITLE</u>	<u>1 FEB 67</u>	<u>30 APR 67</u>
Commanding General	LTC S. R. Larsen	NO CHANGE
Deputy Commanding General	VACANT	VACANT
Chief of Staff	COL (P) L. S. Boatwright	NO CHANGE
Deputy Chief of Staff	COL R. J. Fairfield	COL W. F. Graves
Artillery Officer	EG E. H. DeSaussure Jr.	COL (P) W. O. Quirey
Secretary General Staff	LTC W. R. Healey	LTC D. B. Cullinane Jr.
Information Officer	LTC D. A. Williams	NO CHANGE
Inspector General	LTC J. H. Glandorf	NO CHANGE
Judge Advocate	LTC R. W. Kennedy	NO CHANGE
AC of S, G1	COL G. A. Bone	NO CHANGE
AC of S, G2	COL R. W. Williams	NO CHANGE
AC of S, G3	COL C. P. Hannun	COL E. H. Marks Jr.
AC of S, G4	COL V. Kovalevsky	NO CHANGE
AC of S, G5	VACANT	VACANT
Adjutant General	COL W. H. James	NO CHANGE
Provost Marshal	COL J. J. O'Donnell	NO CHANGE
Signal Officer	COL J. P. Coe Jr.	NO CHANGE
Engineer Officer	COL H. C. Beaty	NO CHANGE
Chaplain	COL T. E. Waldie	NO CHANGE
HQ Commandant	MAJ C. W. Rock	NO CHANGE
Aviation Officer	COL J. W. Marr	NO CHANGE
Chemical Officer	LTC S. E. Anderson	NO CHANGE
Director, DASC	LTC P. P. Hosa (USAF)	COL M. H. Bryant (USAF)
CG, 1st Cav Div (AM)	MG J. Norton	MG J. J. Tolson III
CG, 4th Inf Div (-)	MG W. R. Peers	NO CHANGE
CG, 1st Bde, 101st Abn Div	EG S. H. Matheson	NO CHANGE
CO, 3d Bde, 25th Inf Div	COL J. G. Shanahan	NO CHANGE
CG, Capitol ROK Inf Div	MG B. H. Yoo	NO CHANGE
CG, 9th ROK Inf Div	MG S. D. Lee	NO CHANGE

April 16

103

1 February 1967 - 30 April 1967

UNIT	AUTH	SPDY/AUTH	BATTLE		DEAD	NON-BATTLE		OTHER	RETURN TO DUTY	REPLACEMENT
			KIA	MIA		INJ	SICK			
HQ, I FFORCEV	516	99.4			1	13		1152	113	1075
HQB, I FFORCEV ARTY	195	94.8				3		59	25	67
52d Arty Gp	1800	103.4	3			1		853	442	822
5/27th Arty	516	106.2				2		264	119	156
6/32d Arty	581	93.6				7		6	2	12
I FFORCEV ARTY Adv (Qui Mon)	2517	102.3	1	21	1	8	75	863	547	633
54 S1st Bn	947	90.2						284	74	137
41st CA Co	98	77.5	1					23	5	21
55th IN Det	72	101.3						54	43	21
272d MP Co	182	98.9						144	45	78
297th Trans Car Co	107	98.1						16	12	20
1st Cav Div (AM)	16917	105.4	296	1306	16	65	670	9731	6221	5580
1st Cav Atch	873	101.3	1	9	1		16	420	211	239
4th Inf Div (-)	11803	102.2	182	846	1	64	746	7910	5700	2838
4th Inf Atch	988	99.6	2	3		2	13	295	123	202
3d Bde, 25th Inf Div	3624	94.3	64	269	5	33	110	2506	1232	1626
1st Bde, 101st Abn Div	4724	103.4	25	149	10	65	509	1414	1063	980

Sheet 17 Page 1

USKI	ALPH	SPDY/ARTH	KIA	MIA	MIA	DEAD	INJ	SICK	OTHER	RETURN TO UNIT	REPLACEMENT
II Corps Adv Gp	1310	92.8	5	6					205		183
17th Avn Gp	6003	114.1	15	4	2	6	74	1974		970	3073
Cap ROK Div	14151	100.8	58	201	14	55	643	3272		704	3298
9th ROK Inf	13918	100.1	43	102	11	58	615	86		489	145

- (1) Includes HQ, I FORCEV, HQ Co, I FORCEV, 64th Sngr Let (Terrain), 5th PI Det, 11th PI Det (Press Camp), and 13th Military History Det and 43d AFU.
- (2) Includes Hq Btry 52d Arty Gp; 3 Bn, 6th Arty; 6th Bn, 14th Arty; 1st Bn, 92d Arty; 77 FA Radar Det; and 237 FA Radar Det.
- (3) Includes 7th Bn, 13th Arty; 1st Bn, 30th Arty; 4th Bn, 60th Arty; HNB 8th Bn, 20th Arty; and Btry B 29th Arty and A Btry, 3d Bn, 15th Arty.
- (4) Includes 14th Sig Bn, 167th Sig Co, and 209th Sig Det.

April 17 AGE 2

104

CONFIDENTIAL
MANEUVER BATTALIONS

105

<u>UNIT</u>	<u>STRENGTH</u> <u>AUTH</u>	<u>PERCENT</u> <u>PDY/AUTH</u> <u>28 FEB 67</u>	<u>PERCENT</u> <u>PDY/AUTH</u> <u>31 MAR 67</u>	<u>PERCENT</u> <u>PDY/AUTH</u> <u>30 APR 67</u>
1st Cav Div (AM)				
1st Bn, 5th Cav	767	90.6	97.2	97.2
2d Bn, 5th Cav	767	91.4	96.8	100.0
1st Bn, 7th Cav	767	90.2	97.3	95.7
2d Bn, 7th Cav	767	100.4	101.6	99.3
5th Bn, 7th Cav	767	94.1	97.2	97.3
1st Bn, 8th Cav	767	90.1	97.3	93.6
2d Bn, 8th Cav	767	89.6	97.7	95.1
1st Bn, 12th Cav	767	88.4	97.5	93.8
2d Bn, 12th Cav	767	93.5	96.3	96.8
1st Bn, 9th Cav	792	111.9	114.7	111.3
4th Inf Div (-)				
1st Bn, 8th Inf	789	88.2	78.0	93.0
2d Bn, 8th Inf	789	82.9	91.0	97.1
3d Bn, 8th Inf	789	88.7	96.0	88.3
1st Bn, 12th Inf	789	91.3	98.4	102.1
3d Bn, 12th Inf	789	90.5	89.7	91.8
1st Bn, 22d Inf	789	96.3	95.5	95.5
1st Bn, 69th Arm	571	105.3	103.1	99.7
3d Bde, 25th Inf Div				
1st Bn, 35th Inf	829	84.2	87.5	
2d Bn, 35th Inf	829	86.2	87.5	
1st Bn, 14th Inf	829	90.3	88.8	
1st Bde, 101st Abn Div				
1st Bn, 327th Inf	834	95.3	100.8	89.1
2d Bn, 327th Inf	834	100.0	98.5	85.1
2d Bn, 502d Inf	834	99.0	101.2	96.7

CONFIDENTIAL

File 18